

# AIRGOCLEAN® 11 E

**EN**

**OPERATING MANUAL**  
AIR CLEANER



**Table of contents**

Notes regarding the operating manual..... 2

Safety ..... 2

Information about the device..... 4

Transport and storage..... 5

Assembly and start-up..... 6

Operation ..... 7

Available accessories..... 9

Errors and faults..... 9

Maintenance ..... 10

Technical annex..... 13

Disposal ..... 13

**Notes regarding the operating manual**

**Symbols**

 **Warning of electrical voltage**  
This symbol indicates dangers to the life and health of persons due to electrical voltage.

 **Warning**  
This signal word indicates a hazard with an average risk level which, if not avoided, can result in serious injury or death.

 **Caution**  
This signal word indicates a hazard with a low risk level which, if not avoided, can result in minor or moderate injury.

**Note**  
This signal word indicates important information (e.g. material damage), but does not indicate hazards.

 **Info**  
Information marked with this symbol helps you to carry out your tasks quickly and safely.

 **Follow the manual**  
Information marked with this symbol indicates that the operating manual must be observed.

You can download the current version of the operating manual and the EU declaration of conformity via the following link:

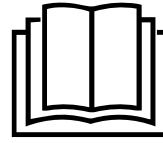

Airgoclean® 11 E



<https://hub.trotec.com/?id=44803>

**Safety**

**Read this manual carefully before starting or using the device. Always store the manual in the immediate vicinity of the device or its site of use.**

-  **Warning**  
**Read all safety warnings and all instructions.** Failure to follow the warnings and instructions may result in electric shock, fire and/or serious injury. **Save all warnings and instructions for future reference.**
- This appliance can be used by children aged from 8 years and above and persons with reduced physical, sensory or mental capabilities or lack of experience and knowledge if they have been given supervision or instruction concerning use of the appliance in a safe way and understand the hazards involved. Children shall not play with the appliance. Cleaning and user maintenance shall not be made by children without supervision.
- Do not use the device in potentially explosive rooms or areas and do not install it there.
  - Do not use the device in aggressive atmosphere.
  - Do not operate the device near open fire or gas appliances.
  - Only put up the device in an upright, stable position on firm ground.
  - Let the device dry out after a wet clean. Do not operate it when wet.
  - Do not use the device with wet or damp hands.
  - Do not expose the device to directly squirting water.
  - Do not expose the device to liquids as it is not protected against splash water.
  - Never insert any objects or limbs into the device.
  - Do not cover or transport the device during operation.
  - Do not sit on the device.
  - This appliance is not a toy! Keep away from children and animals. Do not leave the device unattended during operation.

- Check accessories and connection parts for possible damage prior to every use of the device. Do not use any defective devices or device parts.
- Ensure that all electric cables outside of the device are protected from damage (e.g. caused by animals). Never use the device if electric cables or the power connection are damaged!
- The electrical connection must correspond to the specifications in chapter Technical data.
- Insert the mains plug into a properly secured mains socket.
- Observe the technical data when selecting extensions to the power cable. Completely unroll the extension cable. Avoid electrical overload.
- Before carrying out maintenance, care or repair work on the device, remove the mains plug from the mains socket. Hold onto the mains plug while doing so.
- Switch the device off and disconnect the power cable from the mains socket when the device is not in use.
- Do not under any circumstances use the device if you detect damages on the mains plug or power cable. If the power cable is damaged, it must be replaced by the manufacturer, its service agent or similarly qualified persons in order to avoid a hazard.  
Defective power cables pose a serious health risk!
- When positioning the device, observe the minimum distances from walls and other objects as well as the storage and operating conditions specified in the Technical data chapter.
- Make sure that the air inlet and outlet are not obstructed.
- Make sure that there are no loose items or dirt located in the immediate surroundings of air inlet and air outlet.
- Do not remove any safety signs, stickers or labels from the device. Keep all safety signs, stickers and labels in legible condition.
- Do not expose the device to heat or direct sunlight.
- Make sure that the suction side is kept free of dirt and loose objects.
- Dispose of replaced filters properly, especially after filtering substances hazardous to health.
- Never use the device as storage place or footstep.
- Never select automatic mode if the device is used for virus filtration.

### Intended use

Use the device for cleaning the air as well as for odour elimination (ionization) in interior spaces only whilst adhering to the technical data and safety instructions.

### Improper use

- Do not place the device on wet or flooded ground.
- Do not place any objects, e.g. clothing, on the device.
- Do not use the device outdoors.
- Do not use the device in bathrooms and rooms with a high humidity level.
- Do not use the device in rooms where large amounts of dust are produced, e.g. in production halls, workshops or on construction sites.
- Moreover, the integrated filter system is not suited for removing dusts that are potentially harmful to health (e.g. pollutants) from the air.
- Any operation other than as described in this manual is prohibited. Non-observance renders all claims for liability and guarantee null and void.
- Any unauthorised modifications, alterations or structural changes to the device are forbidden.

### Personnel qualifications

People who use this device must:

- be aware of the dangers that occur when working with electrically driven air cleaners.
- have read and understood the operating manual, especially the Safety chapter.

## Residual risks



### Warning of electrical voltage

Work on the electrical components must only be carried out by an authorised specialist company!



### Warning of electrical voltage

Before any work on the device, remove the mains plug from the mains socket!  
Do not touch the mains plug with wet or damp hands.  
Hold onto the mains plug while pulling the power cable out of the mains socket.



### Warning

Dangers can occur at the device when it is used by untrained people in an unprofessional or improper way!  
Observe the personnel qualifications!



### Warning

The device is not a toy and does not belong in the hands of children.



### Warning

Risk of suffocation!  
Do not leave the packaging lying around. Children may use it as a dangerous toy.

### Note

Do not operate the device without a HEPA carbon filter inserted!

### Note

Do not operate the device without an air filter inserted into the air inlet!  
Without the air filter, the inside of the device will be heavily contaminated. This could reduce the performance and result in damage to the device.

### Note

Do not use abrasive cleaners or solvents to clean the device.

## Behaviour in the event of an emergency

1. Switch off the device.
2. In an emergency, disconnect the device from the mains feed-in: Hold onto the mains plug while pulling the power cable out of the mains socket.
3. Do not reconnect a defective device to the mains.

## Information about the device

### Device description

The device serves to filter the room air with the aim of reducing slight and medium contaminations and odours in order to improve the air quality. It is equipped with a powerful fan sucking in the air at the front. The air flows through the filter and is cleaned. Afterwards the fan releases the clean air back into the room.

The 3-in-1 filter is composed of a HEPA filter, a carbon filter and a prefilter.

The device uses a HEPA filter to remove bacteria, viruses, pollen, dust mite residue, mould fungus spores and other allergens from the air. The integrated prefilter (made of synthetic fibre) filters out large dust particles before the air flows into the HEPA filter. The integrated carbon filter with activated carbon also removes odours from the air.

The HEPA carbon filter is effective against house dust, pet allergens, cigarette smoke, smog and particles which can carry smells and viruses.

The device is equipped with an air quality sensor to display the air quality and control air purification automatically.

Additionally, the device comes with an ionization function. The released ions remove pollen, dust, viruses and bacteria from the room air. Thanks to this air purification method, the quality of the room air can be additionally improved.

The three-stage fan and the uncomplicated, quick filter change ensure easy operation.

Thanks to its compact dimensions the device can be transported conveniently, and owing to its low-noise operation it can be used indoors.

The device has a control panel for operating and controlling the functions.

## Device depiction

### Front view

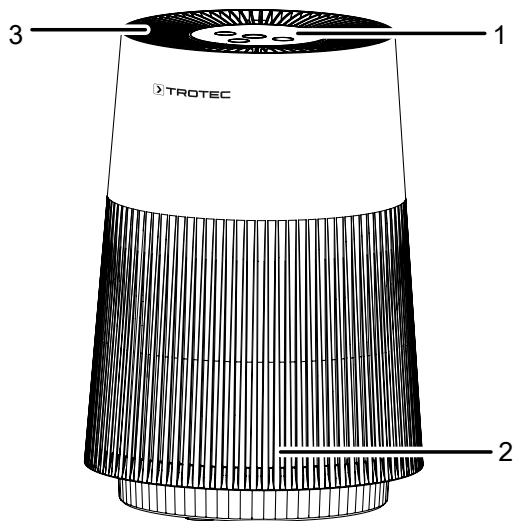

### Rear view

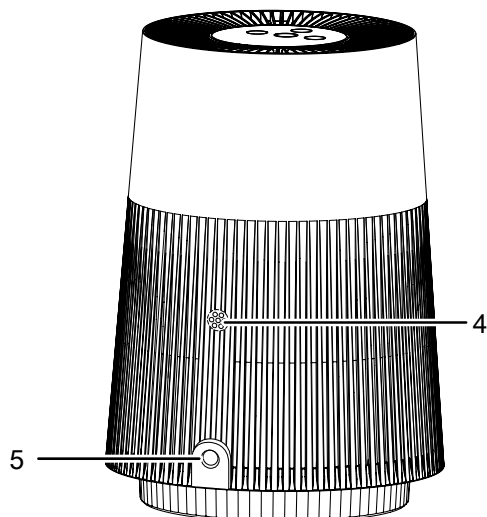

No.	Designation
1	Control panel
2	Air inlet with HEPA carbon filter
3	Air outlet
4	Air quality sensor
5	Adapter connection

## Transport and storage

### Note

If you store or transport the device improperly, the device may be damaged.

Note the information regarding transport and storage of the device.

### Transport

**Before** transporting the device, observe the following:

- Switch the device off.
- Hold onto the mains plug while pulling the power cable out of the mains socket.

**After** transporting the device, observe the following:

- Set up the device in an upright position after transport.

### Storage

When the device is not being used, observe the following storage conditions:

- Dry and protected from frost and heat
- In an upright position where it is protected from dust and direct sunlight
- With a cover to protect it from invasive dust, if necessary

## Assembly and start-up

### Scope of delivery

- 1 x Device
- 1 x HEPA carbon filter
- 1 x adapter
- 1 x Manual

### Unpacking the device

1. Open the cardboard box and take the device out.
2. Completely remove the packaging.
3. Fully unwind the power cable. Make sure that the power cable is not damaged and that you do not damage it during unwinding.

### Start-up

The HEPA carbon filter is pre-installed.

#### Note

Remove the plastic cover from the HEPA carbon filter. To do so, please proceed as described in the chapter Changing the HEPA carbon filter.

When positioning the device, observe the minimum distance from walls or other objects as described in the chapter Technical data.

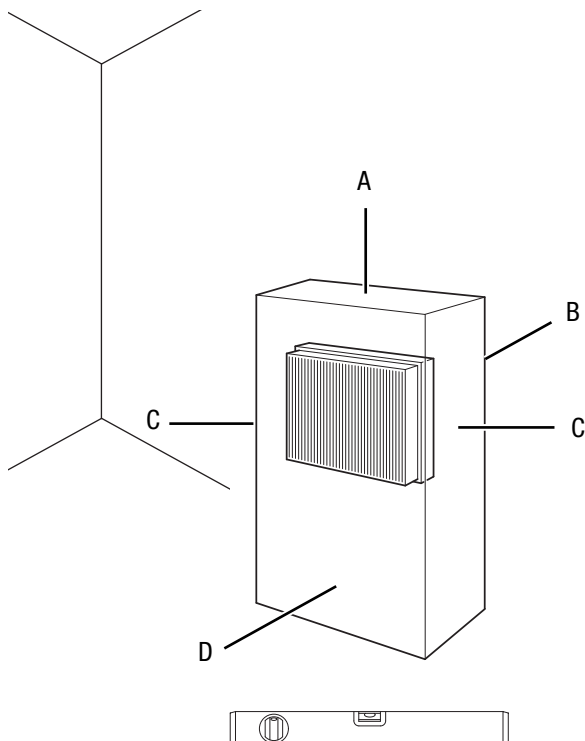

- Do not create tripping hazards when laying the power cable or other electric cables, especially when positioning the device in the middle of the room. Use cable bridges.
- Make sure that extension cables are completely unrolled.
- Position the device near the source of air contamination.
- When positioning the device, keep a sufficient distance to heat sources.
- Make sure that no curtains or other objects interfere with the air flow.
- Make sure that the air inlet and outlet are not obstructed.

### Connecting the power cable

- Insert the adapter of the power adapter (15) into the adapter connection (5) on the device.
- Insert the mains plug into a properly fused mains socket.
  - A brief acoustic signal is emitted.

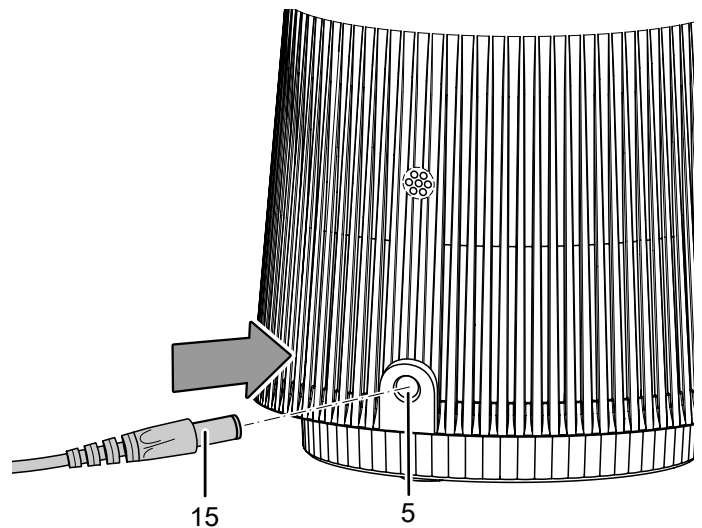

- Before restarting the device, check the condition of the power cable. If there are doubts as to the sound condition, contact the customer service.
- Only put up the device in an upright, stable position on firm ground.

## Operation

### Note

Avoid open doors and windows.

### Control panel

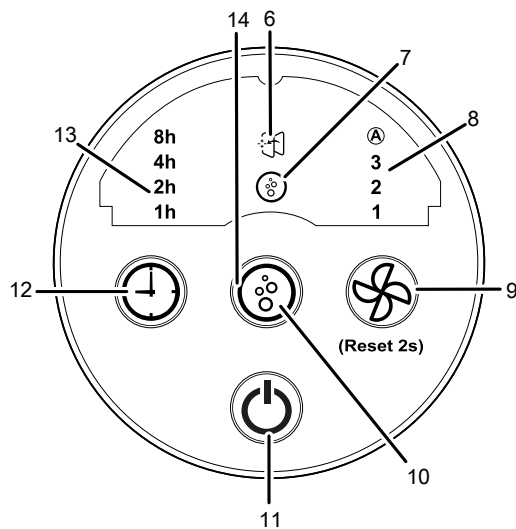

No.	Designation	Meaning
6	Filter change LED	Illuminated when the filter needs to be changed
7	Ionization LED	Illuminated when the <i>ionization</i> function is activated
8	Fan speed LED	Selected fan speed indication: stage 1 = low stage 2 = medium stage 3 = high Ⓐ = automatic mode
9	Speed button	Setting fan speed and automatic mode <i>Reset</i> function: Only press the button for more than 2 seconds if the filter change LED (6) lights up and the filter has been changed
10	Ionization button	Switching ionization on or off
11	On/off button	Switching the device on or off
12	Timer button	Switching on the timer function: 1 h, 2 h, 4 h, 8 h
13	Hours LED	Indication of the number of hours of the activated <i>timer</i> : 1 h, 2 h, 4 h and 8 h
14	Air quality LED	Is illuminated according to the air quality: green = good blue = medium red = poor

### Switching the device on

Once you have completely installed the device as described in the Start-up chapter, you can switch it on.

Afterwards, only the *on/off* key (11) lights up and the device is in standby mode.

- Press the *on/off* (11) button to switch the device on.
  - ⇒ The *fan speed* LED (14) lights up. Before initial start-up, the device starts in its second fan stage.
  - ⇒ The *air quality* LED (14) lights up accordingly to the air quality.

If no operational input is made for 40 seconds, the brightness of the control panel decreases. The full brightness will be restored the next time you make an entry.

### Setting the operating mode:

The device has the following operating modes:

- Ventilation
- Automatic mode

### Ventilation

In *ventilation* mode, you can select all 3 fan speeds manually.

Please proceed as follows to select the fan stages:

- ✓ The device is switched on.
  - Select the desired speed by pressing the *fan speed* button (9).
    - ⇒ The *fan speed* LED (8) of stage 1, 2 or 3 is illuminated.

## Automatic mode

When in automatic mode, the device automatically detects the air quality.

Please proceed as follows to set the automatic mode:

- ✓ The device is switched on.
- 1. Press the *fan speed* button (9) until the automatic mode is selected.
  - ⇒ The  symbol lights up in the *fan speed* LED (8).

After the device has been measuring the air quality, the *air quality* LED (14) will be illuminated in the respective colour: green, blue or red.

<b>Air quality LED</b>	<b>Fan speed LED</b>
Illuminated in green (good air quality)	Stage 1
Illuminated in blue (medium air quality)	Stage 2
Illuminated in red (poor air quality)	Stage 3



### Info

#### Automatic mode and virus filtration

Do not use the automatic mode if the device is used for virus filtration!

The integrated sensors only respond to air pollution caused by fine particulates, pollen or possibly VOC (organic chemical compounds). The device cannot determine the virus load inside the room. It is possible that the automatic mode indicates a "good air quality" even though the virus load in the room is very high. Therefore, when using the device for virus filtration, we recommend that you always select a fixed performance level adapted to the room size or the required circulation rate.

## Setting the timer

You can activate the automatic switch-off function after a preset number of hours by means of the timer.

The number of hours can be set to 1 h, 2 h, 4 h or 8 h.

## Automatic switch-off

- ✓ The device is switched on.
- 1. Press the *timer* button (12) until the desired number of hours is shown on the *hours* LED (13).
  - ⇒ The timer setting equals the desired number of hours.
  - ⇒ The device switches off automatically after the set number of hours has elapsed.

Note regarding automatic switch-off:

- Pressing the Power button (11) deactivates the automatic switch-off function.

## Ionization

With this function, the room air is not only cleaned by means of the HEPA carbon filter, but additionally by means of ions. The released ions remove pollen, dust, viruses and bacteria from the room air.

The function can be set in addition in all operating modes.

1. Press the *ionization* button (10) to switch on the ionization function.
  - ⇒ The *ionization* LED (7) is illuminated.
  - ⇒ The device releases ions and cleans the air.
2. Press the *ionization* button (10) again to deactivate the ionization function.
  - ⇒ The *ionization* LED (7) goes out.

## Memory function

If you switch the device back on from standby mode, the settings selected for the fan speed are saved.

In the event of short power failures, the device starts in *fan speed* level 2 operating mode.

## Shutdown



### Warning of electrical voltage

Do not touch the mains plug with wet or damp hands.

- Drücken Sie die Taste *Ein/Aus* (11).
- Hold onto the mains plug while pulling the power cable out of the mains socket.
- Clean the device according to the Maintenance chapter.
- Store the device according to the Storage chapter.



## Available accessories



### Warning

Only use accessories and additional equipment specified in the operating manual. Using insertion tools or accessories other than those specified in the operating manual may cause a risk of injury.

Designation	Article number
HEPA carbon filter, filter efficiency 99.97 %	7.160.000.511

## Errors and faults

The device has been checked for proper functioning several times during production. If malfunctions occur nonetheless, check the device according to the following list.

### The device does not start:

- Check the power connection.
- Check the power cable and mains plug for damage.
- Check the on-site fusing.
- Wait for 10 minutes before restarting the device. If the device is not starting, have the electrics checked by a specialist company or by Trotec.

### The device is loud or vibrates:

- Check whether the device is set up in a stable and upright position.

### The device gets very warm, is loud or is losing performance:

- Check the air inlets and air filters for dirt. Remove external dirt.

### The device works with reduced capacity:

- Check the HEPA carbon filter for dirt. If necessary, clean or replace the HEPA carbon filter.
- The air outlet is obstructed. Make sure that the air outlet is not blocked. Remove any loose objects from the air outlet.
- The HEPA carbon filter's plastic cover was not removed before installation. Take the HEPA carbon filter out of the plastic cover.

### The device works with no capacity or the air quality does not improve:

- Check whether any windows and/or doors of the room are open. If so, close them.
- The HEPA carbon filter is not installed. Install the HEPA carbon filter.
- Check the minimum distance to walls or other objects. Position the device a little more in the room's centre if required.

### The *air quality* LED is illuminated in red for a longer period of time:

- Check the air quality in the room. The air in the room may be heavily contaminated. Wait for a few minutes to see whether the colour of the *air quality* LED changes.
- The air quality sensor is clogged or soiled. Windows and doors should be closed, otherwise dust and other contamination is able to enter the room. Clean the air quality sensor as described in the Maintenance chapter.

### The device gives off an unpleasant odour:

- Check the HEPA carbon filter for dirt. If necessary, clean or replace the HEPA carbon filter.
- Smoke, e.g. dense tobacco smoke, odours and contaminations may be in the air. Ventilate the room.

### Your device still does not operate correctly after these checks?

Please contact the customer service. If necessary, bring the device to an authorised specialist electrical company or to Trotec for repair.

**Maintenance**

**Maintenance interval**

Maintenance and care interval	before every start-up	as needed	at least every 2 weeks	at least every 4 weeks	at least every 4 months	at least annually
Check air inlets and outlets for dirt and foreign objects and clean if necessary	X			X		
Clean the exterior		X				X
Visually check the inside of the device for dirt		X				X
Check the filter for dirt and foreign objects and clean or replace if necessary	X		X			
Replace the HEPA carbon filter					X	
Cleaning the air quality sensor		X				
Check for damage	X					
Check the attachment screws		X				X
Test run						X

Device type: .....

Device number: .....

Maintenance and care interval	1	2	3	4	5	6	7	8	9	10	11	12	13	14	15	16
Check air inlets and outlets for dirt and foreign objects and clean if necessary																
Clean the exterior																
Visually check the inside of the device for dirt																
Check the filter for dirt and foreign objects and clean or replace if necessary																
Replace the HEPA carbon filter																
Cleaning the air quality sensor																
Check for damage																
Check the attachment screws																
Test run																

First Date: .....	Second Date: .....	Third Date: .....	4. Date: .....
Signature: .....	Signature: .....	Signature: .....	Signature: .....
5. Date: .....	6. Date: .....	7. Date: .....	8. Date: .....
Signature: .....	Signature: .....	Signature: .....	Signature: .....
9. Date: .....	10. Date: .....	11. Date: .....	12. Date: .....
Signature: .....	Signature: .....	Signature: .....	Signature: .....
13. Date: .....	14. Date: .....	15. Date: .....	16. Date: .....
Signature: .....	Signature: .....	Signature: .....	Signature: .....

## Activities required before starting maintenance



### Warning of electrical voltage

Do not touch the mains plug with wet or damp hands.

- Switch the device off.
- Hold onto the mains plug while pulling the power cable out of the mains socket.



### Warning of electrical voltage

**Tasks which require the housing to be opened must only be carried out by authorised specialist companies or by Trotec.**

## Cleaning the housing

Clean the housing with a soft, damp and lint-free cloth. Make sure that no moisture enters the housing. Protect electrical components from moisture. Do not use any aggressive cleaning agents such as cleaning sprays, solvents, alcohol-based or abrasive cleaners to dampen the cloth.

## Visual inspection of the inside of the device for dirt

1. Remove the air filter.
2. Use a torch to illuminate the openings of the device.
3. Check the inside of the device for dirt.
4. If you see a thick layer of dust, clean the inside of the device with a vacuum cleaner.
5. Put the air filter back in.

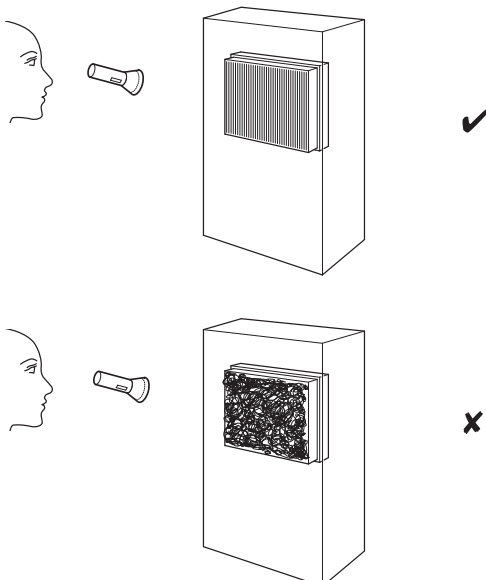

## Changing the HEPA carbon filter

### Note

Do not operate the device without a HEPA carbon filter inserted!

### Note

The HEPA carbon filter is not washable. Do not use water or liquid cleaning agents to clean the HEPA carbon filter.

- The HEPA carbon filter has to be replaced as soon as it is dirty. This is brought to light e.g. by a reduced capacity (see chapter Errors and faults).
- Make sure that the HEPA carbon filter is installed before switching the device on.
- Without the HEPA carbon filter, the device cannot fulfil its air cleaner function, and the inside of the device will be soiled.

The HEPA carbon filter should be replaced in case of heavy soiling.

The lifetime of the HEPA carbon filter is approx. 4 months at a runtime of 12 hours per day and depends on the ambient conditions and the degree of air pollution.

If required, visually inspect the HEPA carbon filter for dirt.

1. Remove the bottom plate (16) by turning it into the *Open* direction of the arrow.

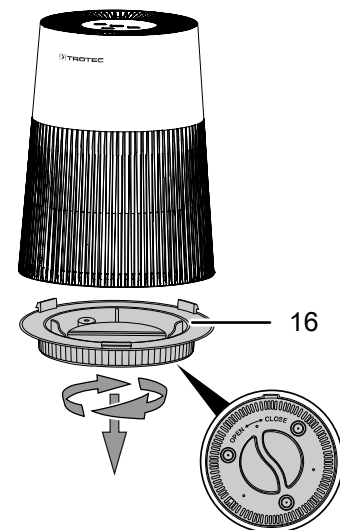

2. Take the used HEPA carbon filter (17) out of the device.

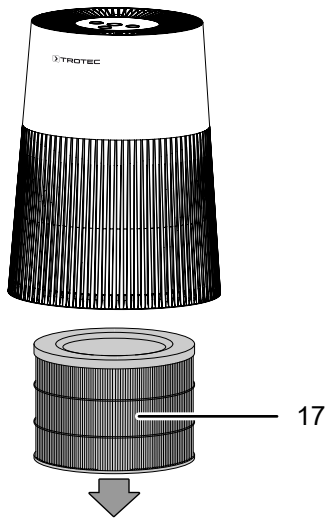

3. Dispose of the used HEPA carbon filter according to the national regulations.  
 4. Take the new HEPA carbon filter out of the plastic cover.  
 5. Insert the new HEPA carbon filter (17) into the device.

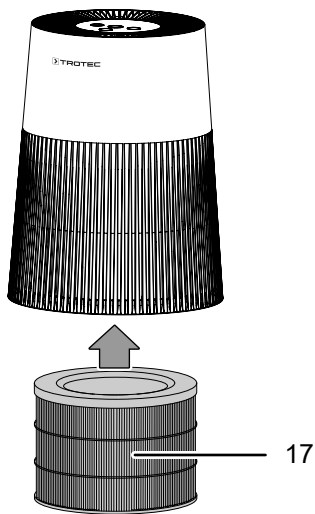

6. Reassemble the bottom plate (16) and the device by turning the bottom plate in the *Close* direction of the arrow. Make sure that the two arrows of the marking (18) are positioned exactly on top of each other.

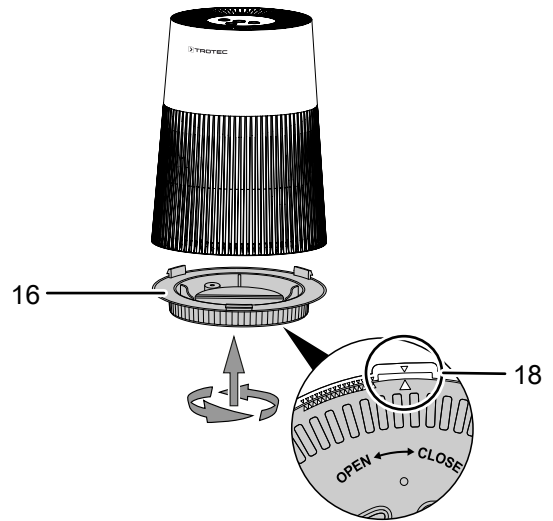

Proceed as follows to reset the *filter change* LED (6).

- ✓ The device is now in standby mode.
1. Press the *fan speed* button (9) for more than 2 seconds.
  2. Press the *on/off* (11) button to switch the device back on.

### Cleaning the air quality sensor

The air quality sensor (4) has to be cleaned once it is soiled and if the *air quality* LED (14) is illuminated in red for a longer period of time (please also refer to the chapter Operation and the chapter Errors and faults).

1. Clean the sensor using a soft, lint-free cloth. Do not use water to clean the sensor as it could damage it.

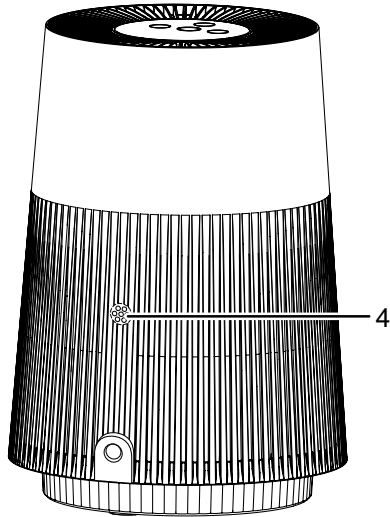

### Activities required after maintenance

If you want to continue using the device:

- Reconnect the device to the mains.

If you do not intend to use the device for a considerable time:

- Store the device according to the Storage chapter.

## Technical annex

### Technical data

Parameter	Value
<b>Model</b>	<b>AirgoClean® 11 E</b>
Air flow rate with HEPA carbon filter	
Fan stage I	42 m <sup>3</sup> /h
Fan stage II	72 m <sup>3</sup> /h
Fan stage III	120 m <sup>3</sup> /h
Ambient temperature	5 °C to 40 °C
Operating range	30 % to 90 % RH
Mains connection (adapter)	100-240 V~ 50-60 Hz
Power consumption	11 W
Nominal current	1.0 A
Dimensions (length x width x height)	238 x 238 x 335 mm
Minimum distance to walls and other objects	
	A: top 30 cm
	B: rear 30 cm
	C: side 30 cm
	D: front 30 cm
Weight	2.5 kg

### Disposal



The icon with the crossed-out waste bin on waste electrical or electronic equipment stipulates that this equipment must not be disposed of with the household waste at the end of its life. You will find collection points for free return of waste electrical and electronic equipment in your vicinity. The addresses can be obtained from your municipality or local administration. For further return options provided by us please refer to our website <https://de.trotec.com/shop/>.

The separate collection of waste electrical and electronic equipment aims to enable the re-use, recycling and other forms of recovery of waste equipment as well as to prevent negative effects for the environment and human health caused by the disposal of hazardous substances potentially contained in the equipment.

Trotec GmbH

Grebener Str. 7  
D-52525 Heinsberg

☎ +49 2452 962-400

☎ +49 2452 962-200

✉ [info@trotec.com](mailto:info@trotec.com)

[www.trotec.com](http://www.trotec.com)