

KF-T120 EC |

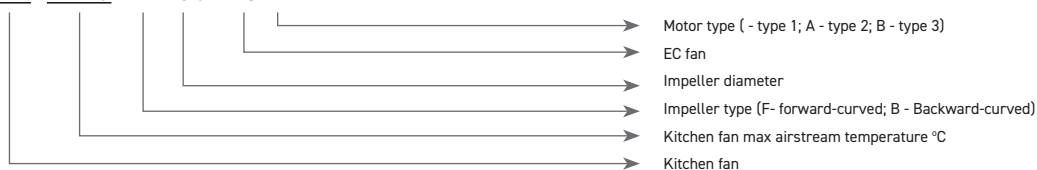

Features	<ul style="list-style-type: none"> > 8 sizes; > Airflow up to 6660 m³/h; > Forward- or Backward-curved galvanized steel impeller; > Max air stream temperature - 120°C; > Fan speed 100% controllable by 0-10 V signal; > Energy efficient; > Easily serviceable.
Power supply	230V/50Hz/1f or 400V/50Hz/3f.
Temperature range	-40°C to +120°C.
Sizes	160, 180, 200, 250, 280, 315, 355, 400.
Construction	<ul style="list-style-type: none"> > Casing: galvanized steel; > Acoustic and thermal wall insulation – 50mm; > Anti-vibration pads; > Easily removable grease tray; > Stainless steel drain connection; > Service door opening on left side; > Galvanized steel roofing; > On/Off safety switch (optional); > Fan: centrifugal impeller and external rotor motor; > Motor protection integrated into motor electronics; > Motor protection class: IP 44/54; > Terminal box protection class: IP55.
Installation	<ul style="list-style-type: none"> > Can be installed outdoors. > Mounting position: vertical.
Speed control options	<ul style="list-style-type: none"> > 10 kΩ potentiometer; > External signal 0-10 VDC/PWM from user controller. > Can be connected directly to optional constant pressure sensors, CO₂, RH

KF T120 F 160 EC A



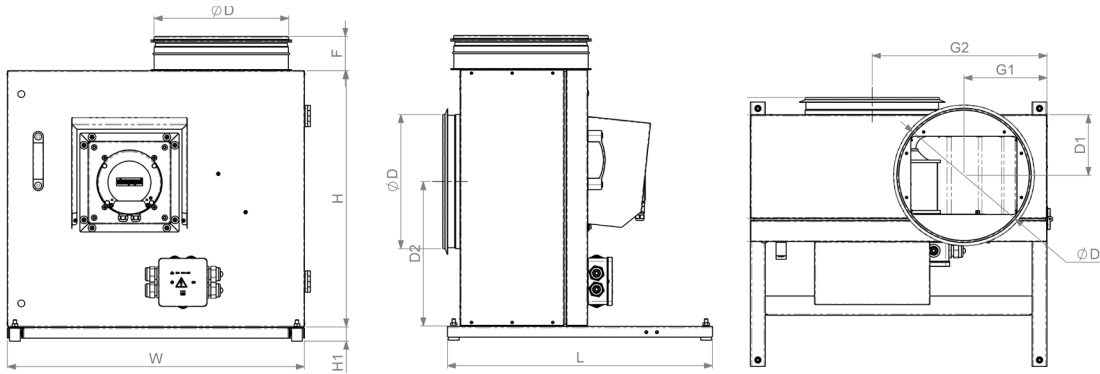

*Estimated dimension

Type	Dimensions [mm]												
	L	W	H	ϕD	L1	L2	F	F1	H1	D1	D2	G1	G2
KF-T120 F 160 EC	420	413	355	200	228	173	81	31	33	109	195	123	242
KF-T120 F 180 EC	420	456	382	200	237	182	80	31	33	112	213	146	270
KF-T120 F 200 EC	500	484	407	200	251	196	80	31	33	119	228	19	285
KF-T120 F 250 EC	620	577	500	315	291	236	80	41	33	126	278	170	341
KF-T120 F 280 EC	620	625	537	315	308	253	81	41	33	153	304	180	367
KF-T120 B 315 EC	620	695	601	315	298	243	80	41	33	142	339	195	410
KF-T120 B 355 EC	620	770	655	400	339	285	190	71	33	163	370	211	455
KF-T120 B 400 EC	620	750	640	400	353	298	190	71	33	170	355	202	450

Type	Accessories									
	Stouch	MTP010*	SMT-D-4P-EL	Main switch	AGO	NPU	RSK	AP	Mute	
KF-T120 F 160 EC	+	+	+	+	-	200	200	200	200	
KF-T120 F 180 EC	+	+	+	+	-	200	200	200	200	
KF-T120 F 200 EC	+	+	+	+	-	200	200	200	200	
KF-T120 F 250 EC	+	+	+	+	315	315	315	315	315	
KF-T120 F 280 EC	+	+	+	+	-	315	315	315	315	
KF-T120 B 315 EC	+	+	+	+	-	315	315	315	315	
KF-T120 B 355 EC	+	+	+	+	-	400	400	-	-	
KF-T120 B 400 EC	+	+	+	+	-	400	400	400	-	

Accessories

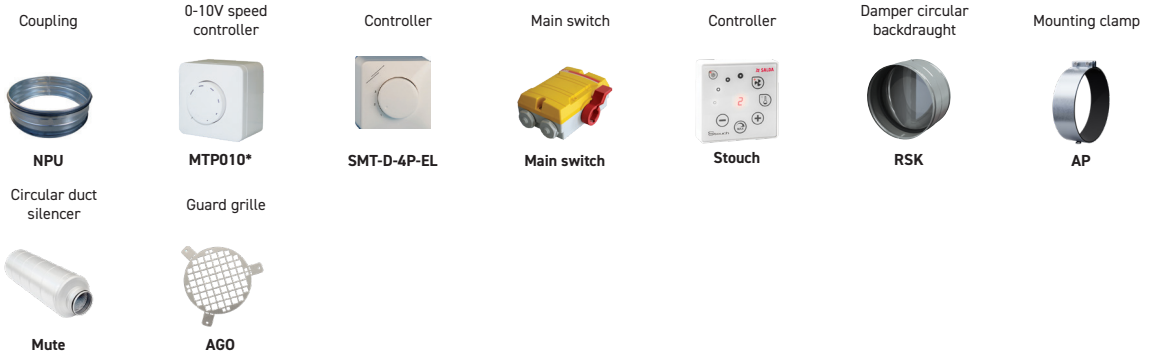

* Pressure transducer S-1141 is supported only with the remote controller Stouch

KF-T120 EC |

———— Performance
 - - - - - Power consumption

1. F 160 EC | 2. F 180 EC | 3. F 200 EC | 4. F 250 EC

		160	180	200	250
Voltage/Frequency	[V/Hz]	~1,230/50	~1,230/50	~1,230/50	~1,230/50
Power consumption	[kW]	0,134	0,200	0,740	0,75
Current	[A]	1,2	1,2	3,2	3,2
Speed	[min ⁻¹]	1500	1500	1490	1360
Max. airflow	[m ³ /h]	1052	1680	2435	3000
Min/Max ambient air temperature	[°C]	-40/+120	-40/+120	-40/+120	-40/+120
Weight	[kg]	17	21	27	35
Protection class:	motor	IP-44	IP-55	IP-55	IP-55
Comply with ERP 2018		*	*	*	*

*Fans for transportation of gases hotter than 100 °C are not subject to ErP regulations.

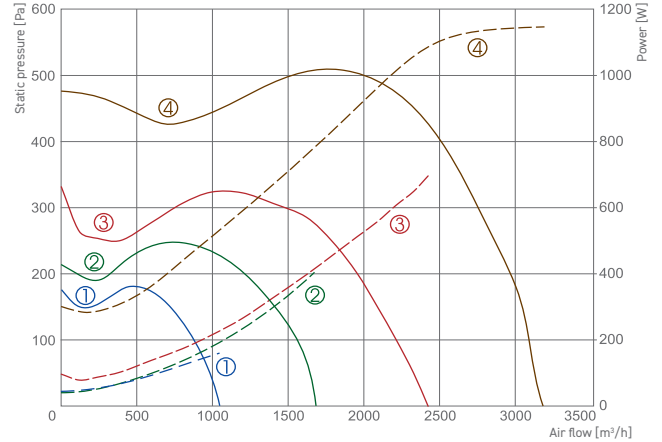

Estimated data

KF-T120 F 160 EC	Lwa total, dB(A)	Lwa, dB(A)						
		125 Hz	250 Hz	500 Hz	1 kHz	2 kHz	4 kHz	8 kHz
Inlet	73	63	66	70	64	59	57	52
Outlet	75	64	70	71	63	62	59	54
Surrounding	58	50	52	54	48	44	41	35

Measured at 802 m³/h, 100 Pa

KF-T120 F 180 EC	Lwa total, dB(A)	Lwa, dB(A)						
		125 Hz	250 Hz	500 Hz	1 kHz	2 kHz	4 kHz	8 kHz
Inlet	81	67	70	80	72	65	64	58
Outlet	83	67	71	82	71	70	66	61
Surrounding	67	57	62	63	58	55	51	47

Measured at 1641 m³/h, 102 Pa

KF-T120 F 200 EC	Lwa total, dB(A)	Lwa, dB(A)						
		125 Hz	250 Hz	500 Hz	1 kHz	2 kHz	4 kHz	8 kHz
Inlet	84	75	76	82	75	71	67	61
Outlet	85	76	79	82	76	70	69	64
Surrounding	71	62	64	68	59	54	51	47

Measured at 2211 m³/h, 103 Pa

KF-T120 F 250 EC	Lwa total, dB(A)	Lwa, dB(A)						
		125 Hz	250 Hz	500 Hz	1 kHz	2 kHz	4 kHz	8 kHz
Inlet	81	72	75	77	70	68	64	57
Outlet	83	74	77	79	72	70	66	62
Surrounding	68	59	63	65	56	52	48	44

Measured at 3112 m³/h, 125 Pa

The fan characteristic curves were determined in accordance with EN ISO 5801. The sound levels were determined in accordance with DIN 45635 resp. ISO 3744 at a distance of 1 m from the fan.

———— Performance
 - - - - - Power consumption

1. F 280 EC | 2. B 315 EC | 3. B 355 EC | 4. B 400 EC

	280	315	355	400
Voltage/Frequency [V/Hz]	~3,400/50	~1,230/50	~1,230/50	~1,230/50
Power consumption [kW]	2,6	0,27	0,27	0,74
Current [A]	4	1,2	1,2	3,2
Speed [min ⁻¹]	1500	1500	1500	1490
Max. airflow [m ³ /h]	6660	2194	3133	3770
Min/Max ambient air temperature [°C]	-40/+120	-40/+120	-40/+120	-40/+120
Weight [kg]	60	40	48	51
Protection class: motor	IP-55	IP-55	IP-55	IP-55
Comply with ERP 2018	*	*	*	*

*Fans for transportation of gases hotter than 100 °C are not subject to ErP regulations.

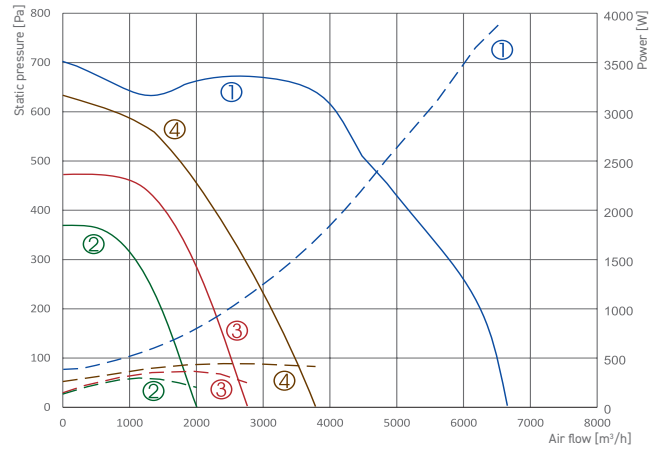

Estimated data

KF-T120 F 280 EC	Lwa total, dB(A)	Lwa, dB(A)						
		125 Hz	250 Hz	500 Hz	1 kHz	2 kHz	4 kHz	8 kHz
Inlet	89	80	84	86	78	72	70	67
Outlet	91	82	85	88	81	75	71	69
Surrounding	76	69	70	72	65	61	56	51

Measured at 6343 m³/h, 207 Pa

KF-T120 B 315 EC	Lwa total, dB(A)	Lwa, dB(A)						
		125 Hz	250 Hz	500 Hz	1 kHz	2 kHz	4 kHz	8 kHz
Inlet	72	64	67	68	64	59	53	49
Outlet	74	65	68	70	65	61	55	52
Surrounding	64	55	61	59	52	48	45	43

Measured at 1780 m³/h, 123 Pa

KF-T120 B 355 EC	Lwa total, dB(A)	Lwa, dB(A)						
		125 Hz	250 Hz	500 Hz	1 kHz	2 kHz	4 kHz	8 kHz
Inlet	76	66	69	72	71	65	56	52
Outlet	78	68	71	75	68	66	59	54
Surrounding	64	56	58	59	55	51	43	39

Measured at 2826 m³/h, 100 Pa

KF-T120 B 400 EC	Lwa total, dB(A)	Lwa, dB(A)						
		125 Hz	250 Hz	500 Hz	1 kHz	2 kHz	4 kHz	8 kHz
Inlet	81	72	71	78	75	70	64	63
Outlet	83	74	77	80	73	71	66	65
Surrounding	69	62	63	65	59	56	51	47

Measured at 3480 m³/h, 149 Pa

The fan characteristic curves were determined in accordance with EN ISO 5801. The sound levels were determined in accordance with DIN 45635 resp. ISO 3744 at a distance of 1 m from the fan.

KF-T120 EC

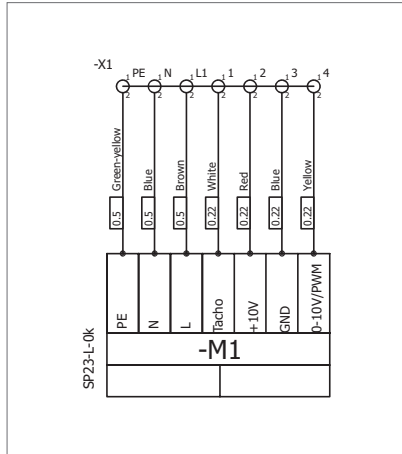

KF T120 F 160 EC
(SP23-L-0k)

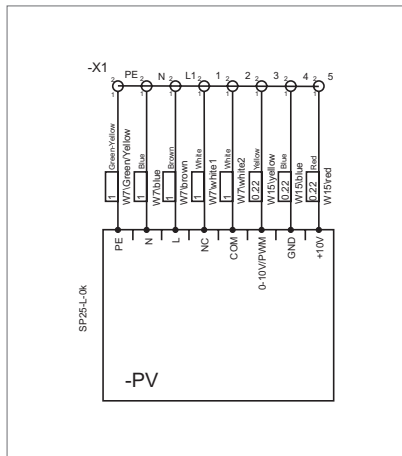

KF T120 F 180 EC, KF T120 B 315 EC, KF T120 B 355 EC
(SP25-L-0k)

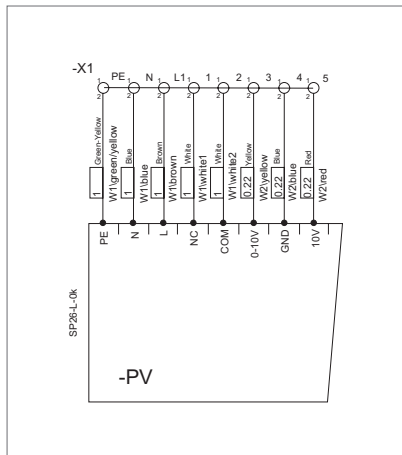

KF T120 F 200 EC, KF T120 F 250 EC, KF T120 B 400 EC
(SP26-L-0k)

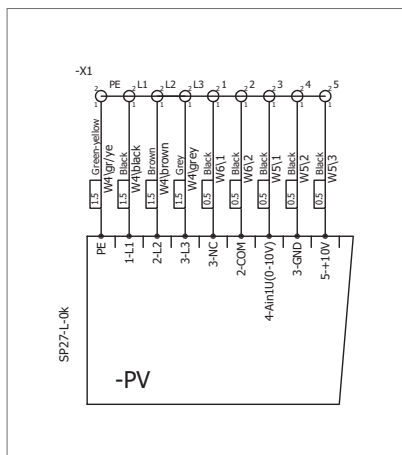

KF T120 F280 EC
(SP27-L-0k)