

Directions for use | EN
Bruksanvisning | SE
Gebrauchsanweisung | DE

RKB

EN | TABLE OF CONTENT

| | |
|--|----------|
| RKB EC | 4 |
| Description | 4 |
| WARRANTY | 4 |
| APPLICATION | 4 |
| HOW TO HANDLE | 5 |
| INSTALLATION | 5 |
| Only – RKB 1000x500 (rectangular) | 5 |
| EC-motor..... | 6 |
| EMC-compatible installation of EXTERNAL control lines..... | 6 |
| OPERATION | 6 |
| MAINTENANCE | 7 |
| Cleaning..... | 7 |
| Access to the fan wheels | |
| RKB 300x150-RKB 1000x500..... | 8 |
| RKB 300x150-RKB 600x350 EC | 8 |
| RKB 700x400-RKB 1000x500 EC..... | 8 |
| FAULT DETECTION | 8 |
| EU-DECLARATION OF CONFORMITY | 9 |

Directions for use in original.

RKB EC

Scan the QR code on the product label or visit www.ostberg.com
For further information about the product.

Description

RKB EC are in-line duct fans with backward curved impellers and swing-out design. The fans are equipped with external rotor induction EC-motor with

maintenance-free sealed ball-bearings. The RKB EC is manufactured from galvanized steel sheet.

WARRANTY

The warranty is only valid under condition that the fan is used according to this "Directions for use" and a regular maintenance has been made and documented. The warrantor is responsible only for the operation if

approved accessories are used. The warranty does not cover product failures caused by accessories/equipment from other manufacturers.

APPLICATION

For technical data please see the label on the product, (picture 1) or www.ostberg.com.



The fan is used for transportation of "clean" air, meaning not intended for flammable substances, explosives, grinding dust, soot, etc.



The fan is intended to be used at maximum the highest voltage and frequency that's stated on the label on the fan.– Example, see picture 1

RKB EC is accessible for the user, according to IEC EN 60335-2-80, to by themselves do the service and maintenance, according to this Directions for use. But before this work the unit must be current less.

With reservation according to EN 60335-1, section 7.12. "This appliance is can be used by children aged from 8 years and above and persons with reduced physical sensory or mental capabilities or lack of experience and knowledge, if they have been given supervision or instruction concerning use of the appliance in a safe way and understand the hazards involved.

Children shall not play with the appliance. Cleaning and user maintenance shall not be made by children without supervision".

- To achieve maximum life time for installations in damp or cold environments, the fan should be operating continuously.
- The fan can be installed outside or in damp environments. Make sure that the fan house is equipped with drainage.
- The fan can be installed in any position, except the model RKB 1000x500 (rectangular) see section – Installation.

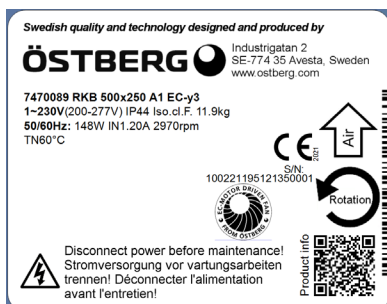

Picture 1 (example)

HOW TO HANDLE

- The fan must be transported in its packing until installation. This prevents transport damages, scratches and the fan from getting dirty.
- Attention, look out for sharp edges.
- Attention! The motor housing can reach temperatures up to 85°C.
- **Waiting time of at least 3 minutes!** Due to internal capacitors in the motor, there is a risk of accidents even after the unit has been switched off by direct contact with live parts or due to parts that have become live

due to faults. The motor control unit cover may only be removed / opened when the power has been disconnected for at least three minutes. The controller housing may only be removed or opened when the power line has been switched off and a period of three minutes has elapsed since switching it off.

- Avoid extreme heat or cold, temperature range -40 °C to 75 °C for storage and transport.
- Avoid prolonged storage; we recommend a maximum of one year (consult the manufacturer before starting if stored for longer).

INSTALLATION

Only – RKB 1000x500 (rectangular)



Improper installation can result in damage to the fan wheel and nozzle (lid facing to the side).

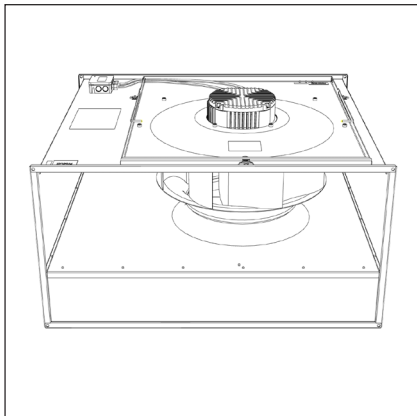

Installed with motor bracket facing up.

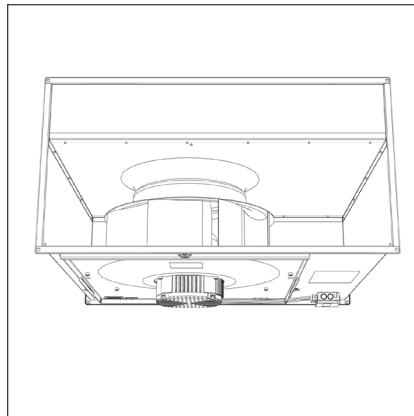

Installed with motor bracket facing down.



Motor bracket facing to the side.

Ensure to install those specific models RKB 1000x500 (rectangular) according to the pictures above, for proper functionality. The other sizes of IRB can be installed with the lid facing to the side, for example on a wall.

All models of RKB

1. The fan must be installed according to the air direction label on the fan.
2. The fan must be connected to duct or equipped with a safety grille.
3. The fan should be installed in a safe way and make sure that no foreign objects are left behind inside.
4. The fan should be installed in a way that makes service and maintenance easy. N.B.! Consider the weight and size of the fan.
5. The fan should be installed in a way that vibrations not can be transferred to duct or building. To provide this, use for example a flange.
6. Electrical installations must be made by an authorized electrician.
7. Electrical installation must be connected to a locally situated isolator switch or by a lockable main switch.
8. Control that the fan is installed and connected electrically in the right way, grounded and with motor protection.
9. For single phase fans a residual current device is used (type A).
10. For 3-phase fans a residual current circuit breaker is used (type B).
11. See Wiring diagram at the lid of the junction box.

EC-motor

- Speed regulating of EC motor can be done with the built-in potentiometer, 0-10 V. Picture 1 & 2
- An external potentiometer can be connected to the terminal if necessary. The internal potentiometer should then be disconnected.
- The fans are equipped with a tachometer, with 1 pulse per revolution.

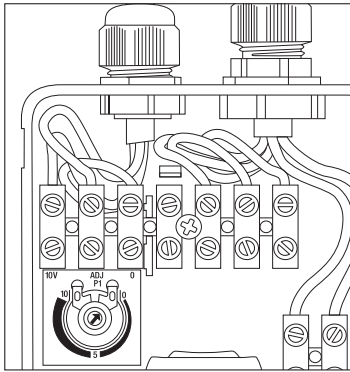

Picture 1

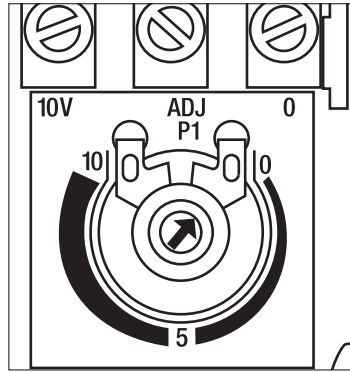

Picture 2

EMC-compatible installation of EXTERNAL control lines

The control cable may not be longer than 30 meter. Screened control cables must be used when the cable length is longer than 20 meter. When using a shielded cable connect the shielding to one side only, i.e. only to the device with the protective ground (keep cable short and with as little inductance as possible!)

Pay attention to sufficient distance from power lines and motor wires to pre-vent interferences. Attention! Ensure correct polarity! Never apply line voltage to analog inputs!

The EC motor has electronically thermal-/over voltage protection.

OPERATION

Before starting, make sure that:

- the current does not exceed more than +5% of what is stated on the label.
- the supplied voltage is within +6% to -10% of the rated voltage.
- no noise appears when starting the fan.
- the rotation direction at 3-phase motors are according to the label.

MAINTENANCE



Before service, maintenance or repair, disconnect power and wait until the impeller has stopped.



Consider the weight of the fan when removing or opening larger fans to avoid injury and damage.

- The fan must be cleaned regularly, at least once per year to maintain the capacity and to avoid unbalance which may cause unnecessary damage to the bearings.
- The fan bearings are maintenance-free and should be replaced only when necessary.
- Make sure that there is no noise from the fan.



Cleaning

When cleaning the fan, high-pressure cleaning or strong dissolvent must not be used. Cleaning should be done without displacing or damaging the impeller.



Access to the fan wheels

RKB 300x150-RKB 1000x500.

1. Loosen the Allen bolts on the hatch (1), different numbers of bolts depending on model M5x10. View A.
2. Loosen the latch at the motor brackets edge (2). Applies to the models: RKB 700x400, RKB 800x500 and RKB 1000x500. View A and B
3. Tilt up/down the motor bracket (3) to access the impeller. For the models: 700x400, 800x500 and 1000x500 there is also a safety arm (4), make sure it is secured. View C.

RKB 300x150-RKB 600x350 EC (picture showing RKB 500x250)

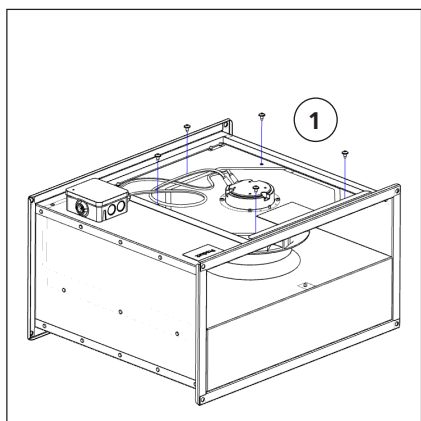

View A

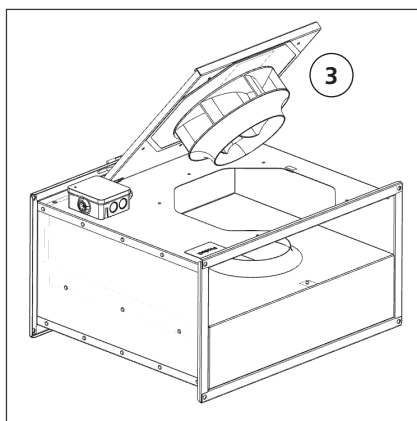

View B

RKB 700x400-RKB 1000x500 EC (picture showing RKB 700x400)

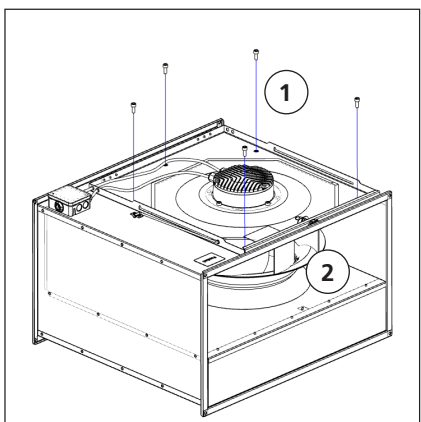

View A

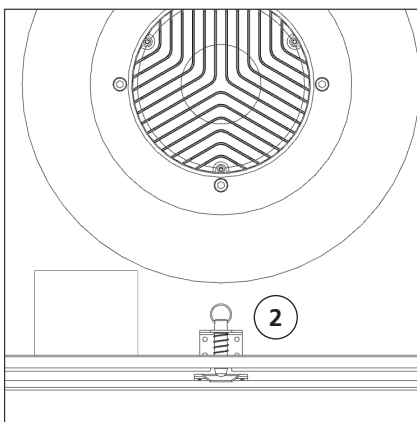

View B

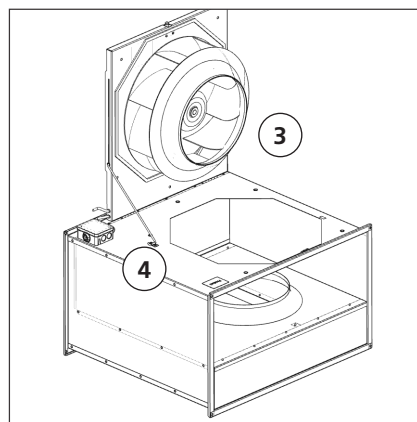

View C

FAULT DETECTION

- Make sure that the power is connected to the fan.
- Disconnect the power and verify that the impeller is not blocked.
- If the previous steps doesn't solve the problem, contact your fan supplier.
- If the fan is returned to the supplier, it must be cleaned, the motor cable must be undamaged and a detailed fault description must be enclosed.

EU DECLARATION OF CONFORMITY

We hereby confirm that our products comply with the requirements in the following EU-directives and harmonised standards and regulations.

Manufacturer: H. ÖSTBERG AB
Industrigatan 2
SE-774 35 Avesta, Sweden
Tel No +46 226 860 00
Fax No +46 226 860 05
<http://www.ostberg.com>
info@ostberg.com
VAT No SE 556301-2201



Products: Duct fans: CK, RK, RKC, RKB, LPKB, LPKBS, IRE, IRB, BFS, BFC
Wall fans: CV, KV, RS
Roof fans: TKK, TKS, TKC, TKV, TKH
Exhaust fans: IFK, IFA, CAU
Supply air units: SAU

This EU declaration is applicable for products including our accessories for mounting and installation only if the installation is made in accordance with the enclosed installation instructions and that the product has not been modified.

Low Voltage Directive (LVD) 2014/35/EU

Harmonised standards:

- EN 60335-1:2012, AC 1, A 13 R1, A 11, A 12, A 13, A 1, A 14, A2, Household and similar electrical appliances - Part 1: General requirements
- EN 60335-2-80:2003, A 1, A 2, Household and similar electrical appliances - safety- Part 2: Particular requirements for fans*
- EN 62233:2008 Measurement methods for electromagnetic fields of household appliances and similar apparatus with regard to human exposure

* Deviations regarding section 24.101 occur. Automatic reset of thermal cut-outs can lead to a sudden start comparable to that of demand-controlled ventilation. These risks are reduced by fixed guards and warnings.

Directive for Electromagnetic Compatibility (EMC) 2014/30/EU

Harmonised standards:

- SS-EN IEC 61000-6-1:2019 Electromagnetic compatibility (EMC) - Generic standards - Immunity for residential, commercial and light-industrial environments
- SS-EN IEC 61000-6-2:2019 Electromagnetic compatibility (EMC) - Generic standards - Immunity for industrial environments
- SS-EN 61000-6-3:2007, A1, Electromagnetic compatibility (EMC) - Generic standards - Emission standard for residential, commercial and light-industrial environments
- SS-EN IEC 61000-6-4:2019 Electromagnetic compatibility (EMC) - Generic standards - Emission standard for industrial environments

Machinery Directive (MD) 2006/42/EC

Harmonised standards:

- EN ISO 12100:2010 Safety of machinery - General principles for design – Risk assessment and risk reduction
- EN ISO 13857:2019 Safety of machinery - Safety distances to prevent hazard zones being reached by upper and lower limbs.
- EN 60204-1:2018 Safety of machinery – Electrical equipment of machines – Part 1: General requirements

Ecodesign Directive 2009/125/EC

Harmonised regulation:

- 1253/2014 Ecodesign requirements for ventilation units
- 1254/2014 Energy labeling of residential ventilation units (Where applicable)

Standards:

- SS-EN 13141-4, SS-EN 13141-8, SS-EN 13141-11 or EN 13053

RoHS 2011/65/EU, 2015/863/EU

Harmonised standards:

- EN IEC 63000:2018

Avesta 2021-11-16

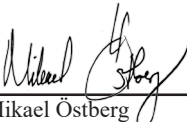
Mikael Östberg
Product Manager

This document is digitally signed.

H. Östberg AB
Box 54
SE-774 22 Avesta
Telefon/Phone: +46 226 860 00
Email: info@ostberg.com
www.ostberg.com

ÖSTBERG 