



**AKU / AKU EKO
KF T120 / KF T120 EC
KUB T120 / KUB EKO
VKAP 3.0 / VKA EKO
VKS / VKSA
VSA 3.0 / VSA EKO
VSV / VSV EKO AL / VSVI / VSVI EKO AL**

EN OPERATION, INSTALLATION & MAINTENANCE INSTRUCTIONS

1. CONTENT

1. CONTENT	2
2. SYMBOLS AND MARKING	3
3. SAFETY INSTRUCTIONS AND PRECAUTIONS	5
4. INFORMATION ABOUT THE PRODUCT	6
4.1. DESCRIPTION	6
4.2. DIMENSIONS AND WEIGHT	6
4.3. TECHNICAL DATA	14
4.4. OPERATING CONDITIONS	18
4.5. STANDARD PACKAGE OF COMPONENTS	18
4.6. DESCRIPTION OF COMPONENTS	19
5. INSTALLATION	20
5.1. RECEPTION OF GOODS	20
5.2. TRANSPORTATION AND STORAGE	20
5.3. UNPACKING	23
5.4. PIPING AND INSTRUMENTATION DIAGRAM	23
5.5. MOUNTING	24
5.6. CONNECTION OF THE AIR DUCTS	29
5.7. CONNECTION OF THE UNIT TO THE ELECTRIC NETWORK	29
5.8. START-UP RECOMMENDATIONS	30
5.8.1. SYSTEM PROTECTION	30
5.8.2. PRE START-UP RECOMMENDATIONS OF THE UNIT (IN THE PRESENCE OF THE END-USER)	31
6. MAINTENANCE	32
6.1. SAFETY INSTRUCTION	32
6.2. GENERAL RECOMMENDATIONS FOR THE MAINTENANCE OF VENTILATION SYSTEM	32
6.3. COVER OPENING	32
6.4. FAN MAINTENANCE	33
7. FAN SPEED CONTROL	35
8. CONNECTION OF ACCESSORIES	36
8.1. CONNECTION OF EC FAN SPEED CONTROLLERS	36
8.2. CONNECTION OF AC FAN SPEED CONTROLLERS	37
8.3. CONNECTION OF ON/OFF SAFETY SWITCH	39
9. ELECTRICAL WIRING DIAGRAMS	40
10. POSSIBLE FAULTS AND TROUBLESHOOTING	44
11. ECODESIGN DATA TABLE	45
12. DECLARATION OF CONFORMITY	50
13. WARRANTY	51
13.1. LIMITED WARRANTY COUPON	51

2. SYMBOLS AND MARKING

 **Warning – pay attention**

 **Additional information**

Apply the technical label on the unit (in an easily accessible location) or on the dashed location of the technical manual to keep the important information about the unit.

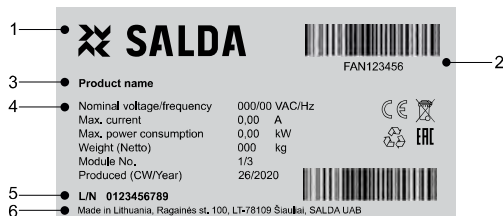

Fig. 2.1 Technical label

1 - Logo; 2 - Product code (SKU); 3 - Product name; 4 - Technical data; 5 - Lot number; 6 - Production place.



Fig. 2.2 Indication for air flow direction.



Fig. 2.3 Indication for duct connection.

ODA - outdoor air; SUP - supply air; ETA - extract air; EHA - exhaust air.

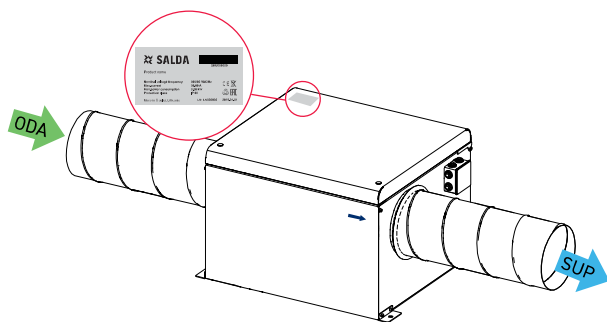

Fig. 2.4 AKU / AKU EKO technical label place and air flow direction

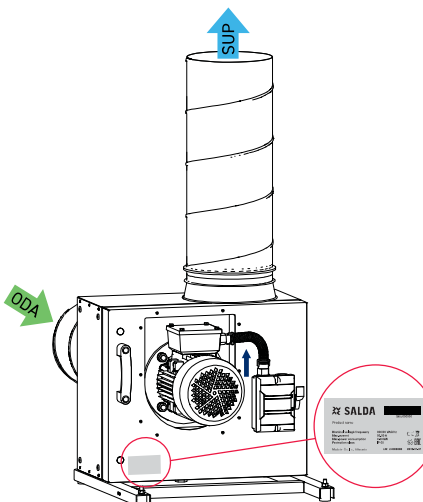

Fig. 2.5 KF T120 / KF T120 EC technical label place and air flow direction

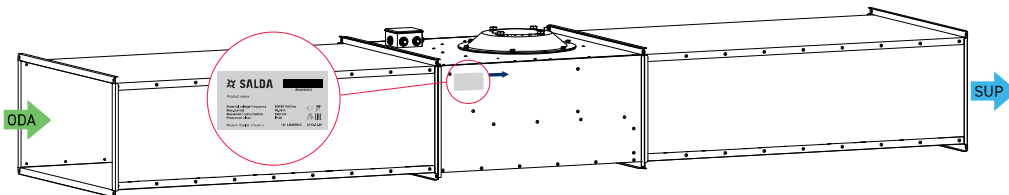

Fig. 2.6 VKS technical label place and air flow direction

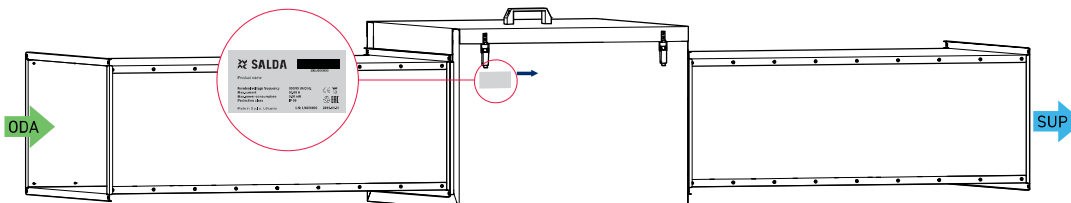

Fig. 2.7 VKSA technical label place and air flow direction

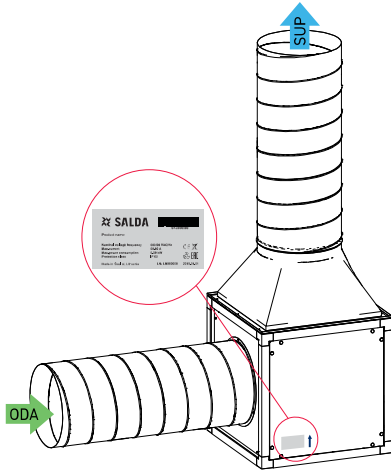

Fig. 2.8 KUB T120 / KUB EKO technical label place and air flow direction

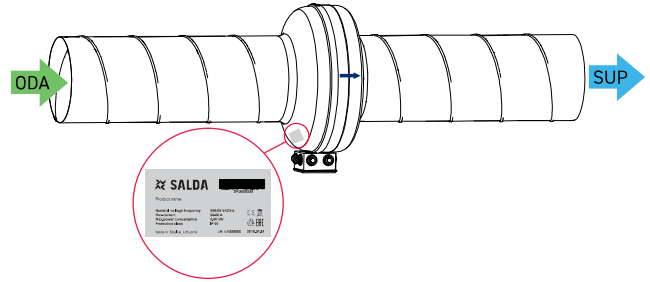

Fig. 2.9 VKAP 3.0 / VKA EKO technical label place and air flow direction

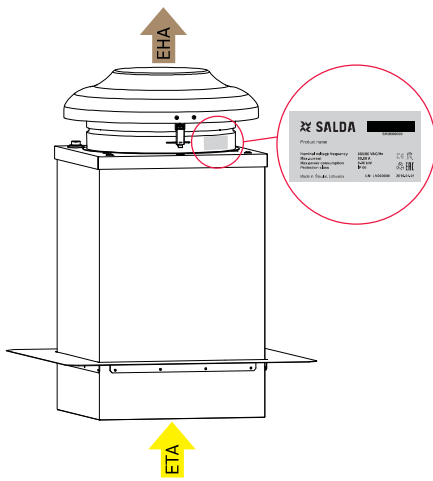

Fig. 2.10 VSA 3.0 / VSA EKO technical label place

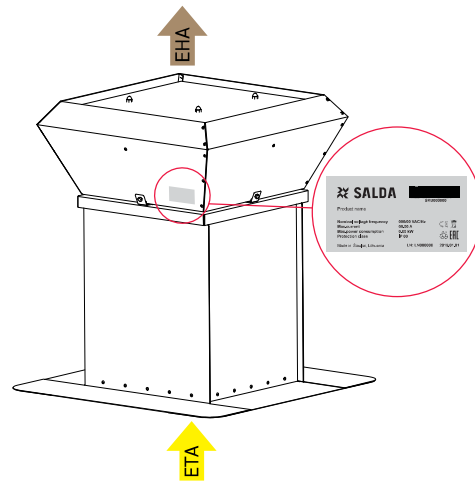

Fig. 2.11 VSV / VSV EKO / VSV EKO AL technical label place

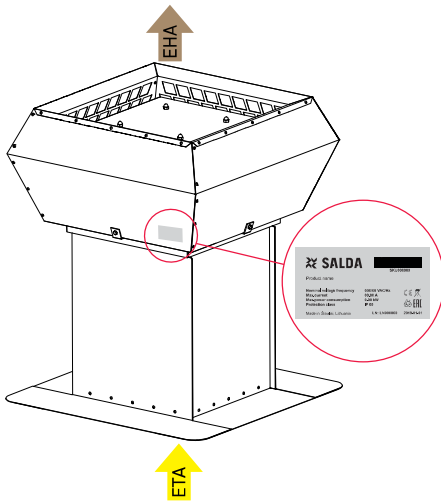

Fig. 2.12 VSVI / VSVI EKO / VSVI EKO AL technical label place

i NOTE. Ducts are not parts of the unit.

3. SAFETY INSTRUCTIONS AND PRECAUTIONS

Read these instructions very carefully before installing and using this equipment. Installation, connection and maintenance should be carried out by a qualified technician and in accordance with local regulations and legislation.

The company shall take no responsibility for the injuries or damaged property if the safety requirements are not followed, or the device is modified without the permission of the manufacturer.

Main safety rules

Danger



- Before carrying out any electrical or maintenance works, make sure that the device is disconnected from the mains and that all moving parts of the device have stopped.
- Make sure that the fans are not accessible through air ducts or branch openings.
- If any liquids on electric parts or connections that bear voltage are noticed, stop the operation of the device.
- Do not plug the device into the mains that differ from the one indicated on the label or on the housing.
- Voltage of the mains should comply with the electrotechnical parameters indicated on the label.
- The device should be earthed in accordance with the regulations on the installation of electric devices. Turning on and using an un-earthed device is not allowed. Follow the requirements specified on the device's labels that indicate danger.

Warnings



- Connection of electricity and maintenance of the device should be performed by qualified personnel only and in accordance with the manufacturer's instructions and safety requirements.
- In order to reduce the risk during installation and maintenance, suitable protective clothing must be worn.
- Beware of sharp angles while carrying out installation and maintenance works.
- Some devices are heavy, you should be very careful while transporting and installing them. Use suitable lifting equipment.
- When connecting electricity to the mains, a circuit breaker of suitable size must be used.

Warning!



- If the device is installed in a cold environment, make sure that all connections and tubes are properly isolated. Intake and exhaust air ducts should be isolated in all cases.
- Openings of the ducts should be covered during transportation and installation.

Before starting up the device



- Make sure, that there are no strange objects inside the device;
 - Manually check fans to make sure they are not stuck or blocked;
 - Check the earthing;
 - Make sure that all components and accessories are connected in accordance with the wiring diagram or provided instructions.
-

4. INFORMATION ABOUT THE PRODUCT

4.1. DESCRIPTION

The fans are designed for the use in the ventilation and air conditioning systems to supply / extract from a room the clean air only (free of chemical compounds causing metal corrosion, of substances aggressive to zinc, plastic and rubber, and of particles of solid, adhesive and fibre materials).



Not suitable for operation in pools, saunas and other similar premises.

4.2. DIMENSIONS AND WEIGHT

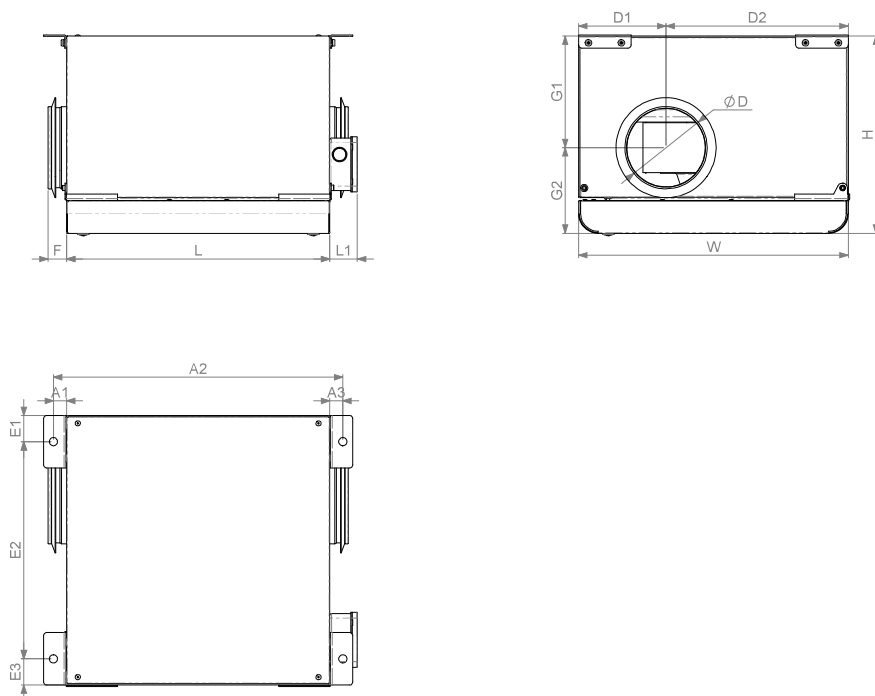

Fig. 4.2.1 AKU / AKU EKO

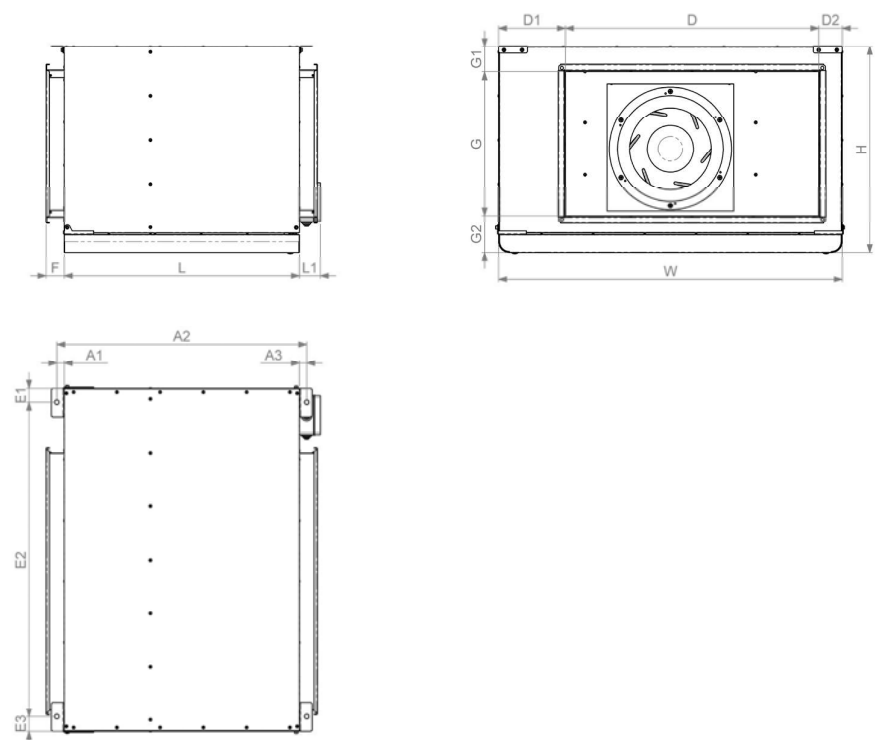

Fig. 4.2.2 AKU 700x400 EKO

AKU		125 D	125 M	160 D	160 M	200 D	200 M	250 D	250 M	250 S	315 D	315 M	400 D	400 S	
A1	[mm]	20													
A2	[mm]	440			484			735	484	735	808	734	808	745	
A3	[mm]	20													
D1	[mm]	133	261		258	222	218	222	228	252	236	252	384		
D2	[mm]	277	149		152	222	476	222	466	516	458	516	384		
E1	[mm]	40													
E2	[mm]	330			364			614	364	614	688	614	688		
E3	[mm]	40													
F	[mm]	28						38					68		
G1	[mm]	170	141		133	250	302	220	302	318	266	303	418		
G2	[mm]	130	159		167	170	197	200	197	252	233	267			
H	[mm]	300			420			499	420	499	570	499	570	685	
L	[mm]	400			444			694	444	694	768	694	768	705	
L1	[mm]	42						60	42			60			
ØD	[mm]	125	160		200			250			315		400		
W	[mm]	410				444			694	444	694	768	694	768	
Weight	[kg]	13,6	12	14	13,5	13,8	17	40	17,3	38	64	48	75	70	

AKU EKO		125	160	200	250	315	700 X 400	700 X 400 S	
A1	[mm]	20							
A2	[mm]	441	590	640		477	691		
A3	[mm]	20							
D	[mm]	-					700		
D1	[mm]	205	149	170	194	298	185		
D2	[mm]	205	336	375	351	298	65		
E1	[mm]	40							
E2	[mm]	330	405	465		515	870		
E3	[mm]	40							
F	[mm]	28			38			50	
G	[mm]	-							
G1	[mm]	164	193	285	233	238	69		
G2	[mm]	161	147	167	192	237	101		
H	[mm]	325	340	425		475	570		
L	[mm]	400	550	600		437	650		
L1	[mm]	49				45	58		
ØD	[mm]	125	160	200	250	315	-		
W	[mm]	410	485	545		595	950		
Weight	[kg]	11,9	18,6	24,4	24,3	22,7	83	86	

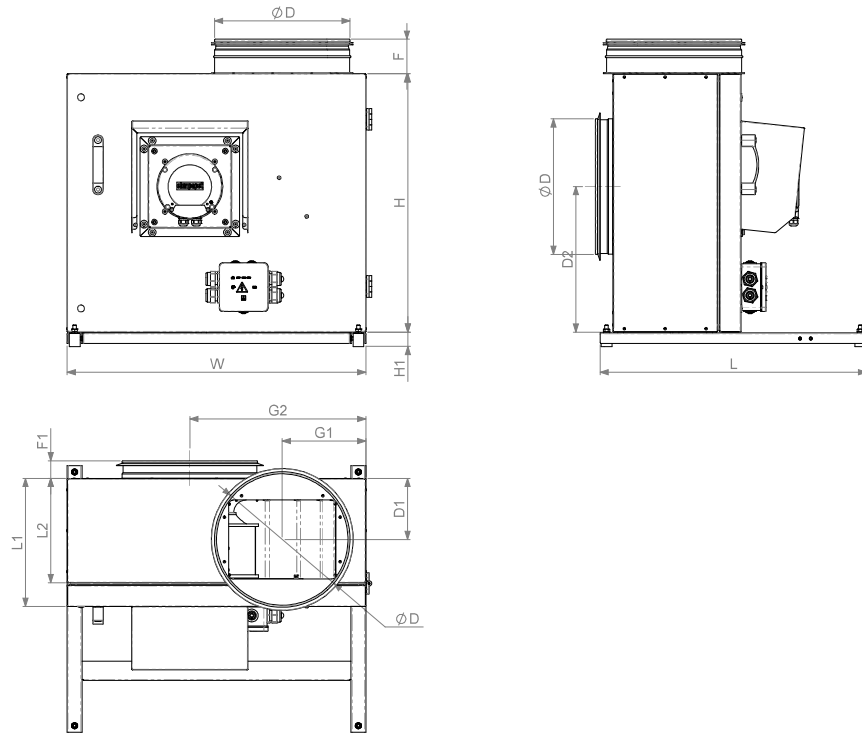

Fig. 4.2.3 KF T120 / KF T120 EC

KF T120		160-4 L3	180-4 L3	200-4 L3	225-4 L3	250-4 L3	280-4 L3	315-4 L3	355-4 L3	400-4 L3
L	[mm]	420	414	500		620				
W	[mm]	413	456	484	537	577	626	695	770	750
H	[mm]	355	382	407	456	500	537	601	655	640
H1	[mm]	34								
L1	[mm]	228	237	251	277	291	308	298	340	353
L2	[mm]	173	182	196	222	236	253	243	285	298
D1	[mm]	109		117	132	146	153	141	170	169
D2	[mm]	195	213	228	253	278	304	339	370	355
ØD	[mm]	200			250	315			400	
G1	[mm]	123	145	149	161	170	180	195	211	202
G2	[mm]	242	270	285	320	341	367	410	455	451
F	[mm]	84		83		93			193	191
F1	[mm]	31			42	41			71	
Weight	[kg]	21	31	32	38	49	61	46	55	60

KF T120 EC		F 160	F 180	F 200	F 250	F 280	B 315	B 355	B 400	
L	[mm]	420		500	620					
W	[mm]	413	456	484	577	625	695	770	750	
H	[mm]	355	382	407	500	537	601	655	640	
H1	[mm]	33								
L1	[mm]	228	237	251	291	308	298	339	353	
L2	[mm]	173	182	196	236	253	243	285	298	
D1	[mm]	109	112	119	126	153	142	163	170	
D2	[mm]	195	213	228	278	304	339	370	355	
ØD	[mm]	200			315		142	400		
G1	[mm]	123	146	149	170	180	195	211	202	
G2	[mm]	242	270	285	341	367	410	455	450	
F	[mm]	81	80			81	80	190		
F1	[mm]	31			41			71		
Weight	[kg]	17	21	26	34	61	40	48	51	

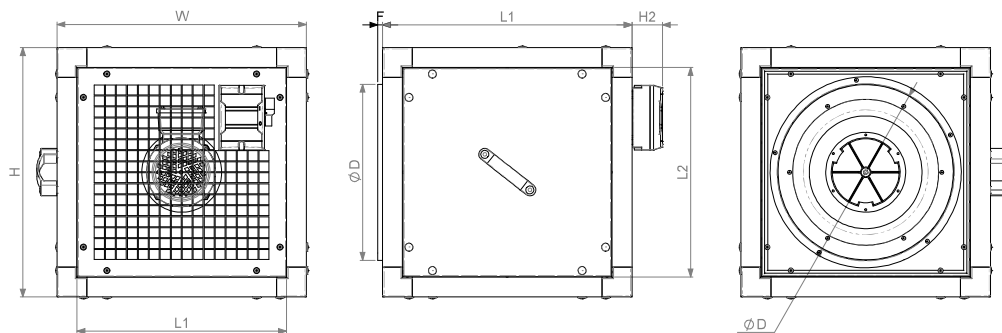

Fig. 4.2.4 KUB T120

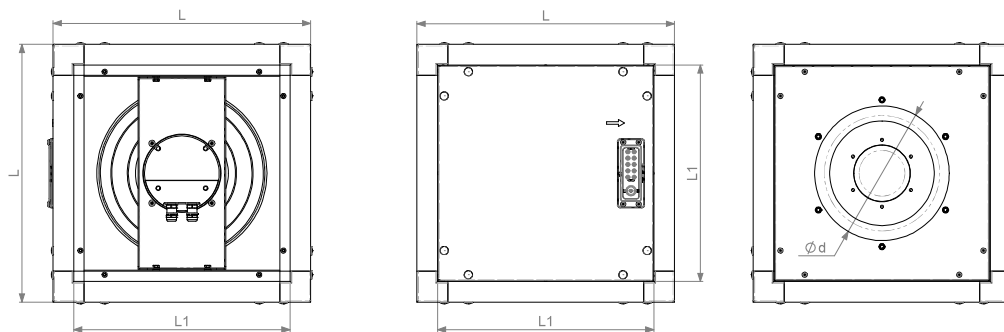

Fig. 4.2.5 KUB EKO

KUB T120		355-4 L3	400-4 L3	450-4 L3	500-4 L3	560-4 L3	630-4 L3	
L	[mm]	500	670			800	866	
W	[mm]	500	670		720	800	866	
H	[mm]	500	670			800	866	
H2	[mm]	61						
L1	[mm]	420	590		640	720	786	
L2	[mm]	420	590			720	786	
ØD	[mm]	355	400	450	500	560	630	
F	[mm]	9						
Weight	[kg]	36	60	61	66	99	148	

KUB EKO		50-355	67-400	67-500	80-560	80-630	100-630
L	[mm]	500	670		800		1000
L1	[mm]	420	590		720		920
Ød	[mm]	261	325	412	461	512	510
Weight	[kg]	28	50	51	75	86	115

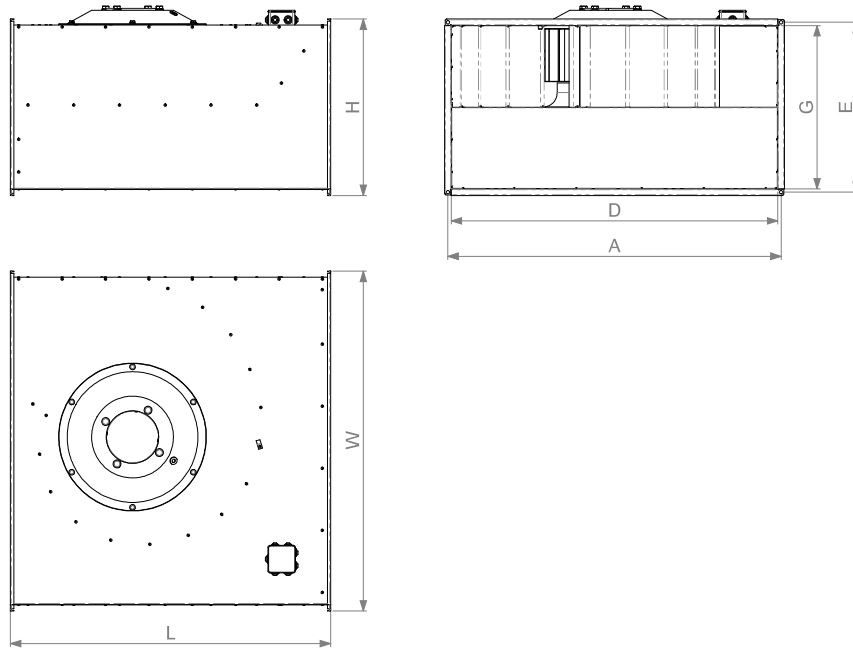

Fig. 4.2.6 VKS

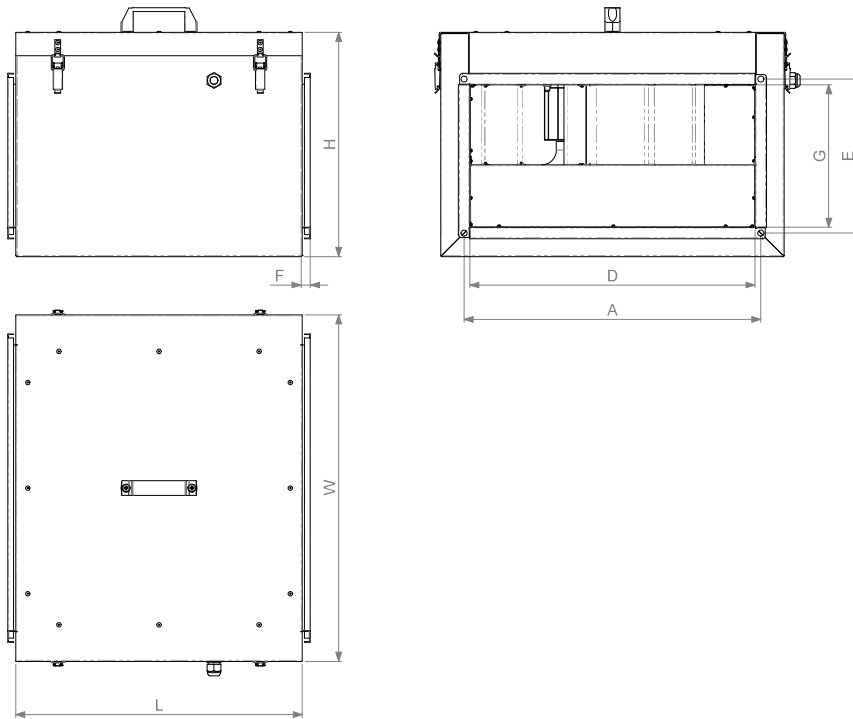

Fig. 4.2.7 VKSA

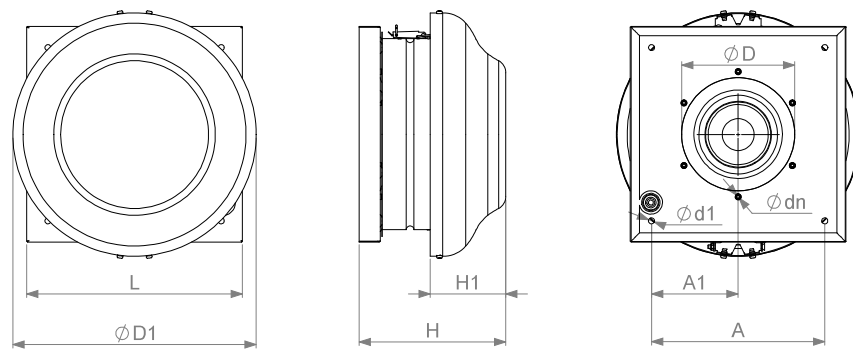

Fig. 4.2.8 VSA / VSA EKO

VKS		400-200-4 L1	400-200-4 L3	500-250-4 L1	500-250-4 L3	500-300-4 L1	500-300-4 L3	600-300-4 L1	600-300-4 L3	600-350-4 L1	600-350-4 L3	700-400-4 L3	800-500-4 L3	800-500-6 L3	1000-500-4 L3
L	[mm]	445		530		560		640		700		780	880		980
W	[mm]	440		540				640				740	840		1040
H	[mm]	240		290		340				390		440	540		
D	[mm]	400		500				600				700	800		1000
G	[mm]	200		250		300				350		400	500		
E	[mm]	220		270		320				370		420	520		
A	[mm]	420		520				620				720	820		1020
Weight	[kg]	12		17	16	21	38	31		42	37	61	80	70	96

VKSA		400-200-4 L1	400-200-4 L3	500-250-4 L1	500-250-4 L3	500-300-4 L1	500-300-4 L3	500-300-6 L1	600-300-4 L1	600-300-4 L3	600-300-6 L1	600-350-4 L1	600-350-4 L3	700-400-4 L3	800-500-6 L3
L	[mm]	417		502		533		612				672		752	852
W	[mm]	507		607		609		726				702		811	911
H	[mm]	338		393		441				444		493		564	665
D	[mm]	400		500				600				700		800	
G	[mm]	200		250		300				350		400	500		
E	[mm]	220		270		320				370		420	520		
A	[mm]	420		520				620				720	820		
F	[mm]	14													
Weight	[kg]	19		31	23	38		50		55	64		98	119	

VSA 3.0		190 L	190 S	220 M	220 S	225 L	250 L
A	[mm]	245		330			
A1	[mm]	122,5		165			
d1	[mm]	8					
dn		M4		M5			
D1	[mm]	344		450			
H	[mm]	207	214		245,5		
H1	[mm]	107		109			
L	[mm]	305		405			
ØD	[mm]	160		200			
Weight	[kg]	4,3		6,5		7,1	7,5

VSA EKO		190	220	225	250	
A	[mm]	245		330		
A1	[mm]	122,5		165		
d1	[mm]	8				
dn		M4		M5		
D1	[mm]	344		450		
H	[mm]	207	241	238	131,5	
H1	[mm]	107		109		
L	[mm]	305		405		
ØD	[mm]	160		200		
Weight	[kg]	4	6,1	6,2	9,8	

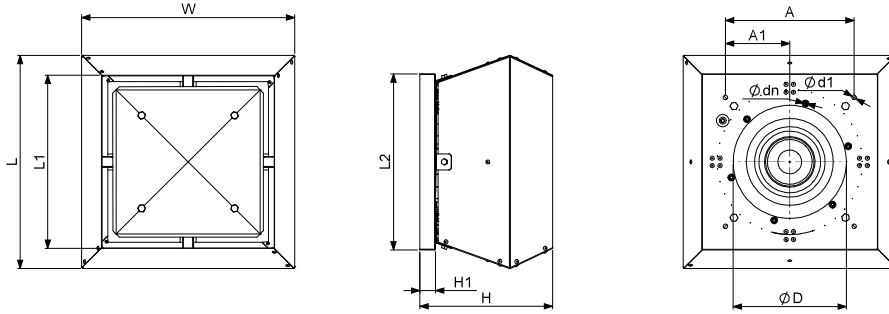

Fig. 4.2.9 VSV / VSV AL / VSV AL EKO

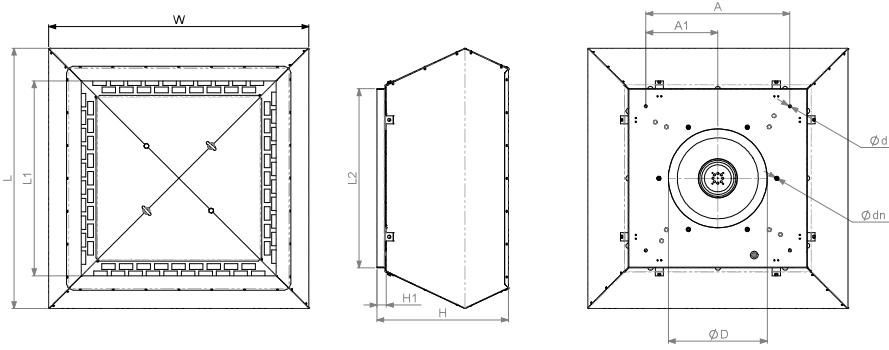

Fig. 4.2.10 VSVI / VSVI AL / VSVI AL EKO

VSV		250-2SL1	311-4 L1	311-4 L3	355-4 L1	355-4 L3	400-4 L1	400-4 L3	450-4 L1	450-4 L3	500-4 L3	560-4 L3	630-4 L3	630-6 L3
L	[mm]	405	585		725				900		1065	1155		
L1	[mm]	330	497		610				704	705	886	977		
L2	[mm]	335	435		595				665		939			
H	[mm]	252	286		420				485		500	609		
H1	[mm]	30												
A	[mm]	245	330		450				535		750			
A1	[mm]	122,5	165		225				267,5		375			
d1	[mm]	8	10		11						12			
dn		M6				M8								
D	[mm]	215	257		290		325		367		408	460	510	
W	[mm]	405	585		725				900		1065	1155		
Weight	[kg]	11	21,3	26	32,2	31	35	33	56	52	60	88	136	108

VSV EKO AL		311-L1	355-L1	400-L1	450-L3	500-L3	560-L3	630-L3
L	[mm]	556	723		900		1152	
L1	[mm]	470	610		705		980	977
L2	[mm]	435	595		665		938	939
H	[mm]	323	420		485		609	
H1	[mm]	30						
A	[mm]	330	450		535		750	
A1	[mm]	165	225		267,5		375	
d1	[mm]	9,5	11			12	12,5	
dn		M6		M8				
D	[mm]	285	438			605		
W	[mm]	556	723		900		1152	
Weight	[kg]	15	22	24	50	36	66	78

VSVI / VSVI AL		311-4 L1	311-4 L3	355-4 L1	355-4 L3	400-4 L1	400-4 L3	450-4 L1	450-4 L3	500-4 L3	560-4 L3	630-4 L3	630-6 L3	
L	[mm]	674		845				966			1265			
L1	[mm]	470		620				723			944			
L2	[mm]	435		595				665			939			
H	[mm]	369		422		420		488			611			
H1	[mm]	30	34	30	36	30	36	35						
A	[mm]	330		450				535			750			
A1	[mm]	165		225				268			375			
d1	[mm]	10		11						12				
dn		M6		M8						M10		M8		
D	[mm]	257		290		325		367		408		460		510
W	[mm]	675		845				966			1265			
Weight	[kg]	26		43	38	46	29	61	41	59	114	140	124	

VSVI EKO AL		311-L1	311-L1 CPG	355-L1	355-L1 CPG	400-L1	400-L1 CPG	450-L3	450-L3 CPG	500-L3	500-L3 CPG	560-L3	560-L3 CPG	630-L3	630-L3 CPG
L	[mm]	674		844				966			1265				
L1	[mm]	470		619				723			944	955	944		
L2	[mm]	435		595				665			938		939		
H	[mm]	369		420		422		488			611				
H1	[mm]	34		30	35										
A	[mm]	330		450				535			750				
A1	[mm]	165		225				267,5			375				
d1	[mm]	9,5		11						12		12,5			
dn		M6				M8				M10		M8			
D	[mm]	234		262		324		364		408		460		510	
W	[mm]	674		844				966			1265				
Weight	[kg]	19	22			40	42		54	48,7	60,1	91,2	99	91	95

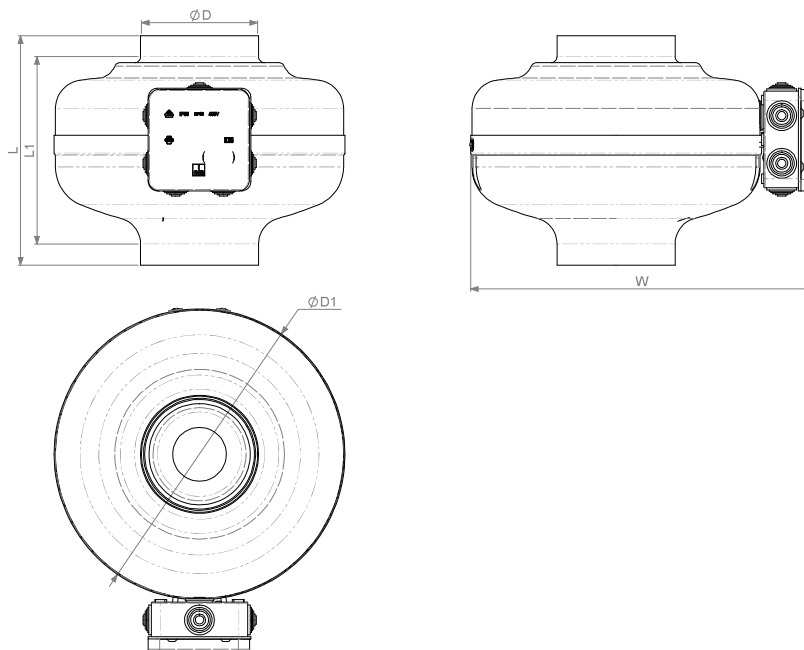

Fig. 4.2.11 VKAP 3.0 / VKA EKO

VKAP 3.0		100 LD	100 MD	125 LD	125 MD	150 LD	160 LD	160 MD	200 LD	200 MD	250 LD	250 MD	315 LD	315 MD
D1	[mm]	244		243		344		244	344				402	
L	[mm]	192		184		222	221	189	231	219	233	225	256	243
L1	[mm]	157		146		172	170	143	179	167	173	165	188	175
ØD	[mm]	100		125		150	160		200		250		315	
W	[mm]	287		285		386		286	386				443	
Weight	[kg]	2,7		2,6		4,1	4	2,7	4,5	4,1	4,4	4,1	6,3	5,6

VKA EKO		125	150	160	200	250	315
D1	[mm]	245	344	245	345		402
L	[mm]	207	222	199	241	245	247
L1	[mm]	176	172	155	188	185	179
ØD	[mm]	125	150	160	200	250	315
W	[mm]	289	386	289	389		446
Weight	[kg]	2,2	3,1	2,2	3,7	3,6	4,7

4.3. TECHNICAL DATA

AKU		125 D	125 M	160 D	160 M	200 D	200 M	250 D	250 M
phase/voltage	[50 Hz/VAC]	~1 / 230	~1 / 230	~1 / 230	~1 / 230	~1 / 230	~1 / 230	~1 / 230	~1 / 230
power/current	[kW/A]	0,17 / 0,73	0,17 / 0,37	0,28 / 1,2	0,17 / 0,73	0,28 / 1,2	0,17 / 0,75	0,69 / 3	0,26 / 1,12
speed	[min ⁻¹]	2480	2200	2647	2480	2647	1550	1190	2000
capacitor	[µF]	4	2	5	4	5	4	10	5
protection class		IP44	IP44	IP44	IP44	IP44	IP44	IP54	IP44
wiring diagram		#5	#6	#6	#5	#6	#5	#7	#6

AKU		250 S	315 D	315 M	400 D	400 S
phase/voltage	[50 Hz/VAC]	~1 / 230	~1 / 230	~1 / 230	~1 / 230	~1 / 230
power/current	[kW/A]	0,28 / 1,23	2,4 / 11	1,15 / 5,1	2,4 / 11	1,5 / 6,7
speed	[min ⁻¹]	2750	1340	1210	1340	1500
capacitor	[µF]	10	35	16	35	25
protection class		IP44	IP54	IP54	IP54	IP54
wiring diagram		#6	#7	#7	#7	#8

AKU EKO		125	160	200	250	315	700X400	700X400 S
phase/voltage	[50 Hz/VAC]	~1 / 230	~1 / 230	~1 / 230	~1 / 230	~1 / 230	~1 / 230	~1 / 230
power/current	[kW/A]	0,05 / 0,4	0,08 / 0,75	0,17 / 1,4	0,17 / 1,4	0,38 / 2,5	0,87 / 3,92	1,3 / 5,67
speed	[min ⁻¹]	4525	3200	3230	2860	3370	2200	2390
control input	[VDC]	0-10	0-10	0-10	0-10	0-10	0-10	0-10
protection class		IP44	IP54	IP54	IP54	IP54	IP54	IP54
wiring diagram		#1	#1	#2	#1	#3	#4	#4

KF T120 EC		F 160	F 180	F 200	F 250	F 280	B 315	B 355	B 400
phase/voltage	[50 Hz/VAC]	~1 / 230	~1 / 230	~1 / 230	~1 / 230	~3 / 400	~1 / 230	~1 / 230	~1 / 230
power/current	[kW/A]	0,13 / 1,2	0,2 / 1,2	0,74 / 0,32	0,74 / 3,2	2,6 / 4	0,27 / 1,2	0,27 / 1,2	0,74 / 3,2
speed	[min ⁻¹]	1500	1500	1490	1490	1500	1500	1500	1490
control input	[VDC]	0-10	0-10	0-10	0-10	0-10	0-10	0-10	0-10
protection class		IP44	IP55	IP55	IP55	IP55	IP55	IP55	IP55
wiring diagram		#10	#9	#10	#10	#11	#9	#9	#9

KF T120		160-4 L3	180-4 L3	200-4L3	225-4L3	250-4L3	280-4L3	315-4 L3
phase/voltage	[50 Hz/VAC]	~3 / 400	~3 / 400	~3 / 400	~3 / 400	~3 / 400	~3 / 400	~3 / 400
power/current	[kW/A]	0,18 / 0,57	0,37 / 1,1	0,55 / 1,49	0,75 / 1,93	1,6 / 3,37	2,2 / 4,84	0,25 / 0,75
speed	[min ⁻¹]	1310	1340	1390	1390	1400	1420	1330
protection class		IP55	IP55	IP55	IP55	IP55	IP55	IP55
wiring diagram		#12*	#12*	#12*	#12*	#12*	#12*	#12*

KF T120		355-4 L3	400-4 L3
phase/voltage	[50 Hz/VAC]	~3 / 400	~3 / 400
power/current	[kW/A]	0,37 / 1,1	0,55 / 1,49
speed	[min ⁻¹]	1340	1390
protection class		IP55	IP55
wiring diagram		#12*	#12*

KUB T120		355-4L3	400-4L3	450-4L3	500-4L3	560-4L3	630-4L3
phase/voltage	[50 Hz/VAC]	~3 / 400	~3 / 400	~3 / 400	~3 / 400	~3 / 400	~3 / 400
power/current	[kW/A]	0,37 / 1,1	0,75 / 1,49	1,1 / 2,5	1,5 / 3,3	3 / 6,39	4,88 / 8,9
speed	[min ⁻¹]	1340	1390	1440	1440	1410	1450
protection class		IP55	IP55	IP55	IP55	IP55	IP55
wiring diagram		#12*	#12*	#12*	#12*	#12*	#13*

KUB EKO		50-355	67-400	67-500	80-560	80-630	100-630
phase / voltage	[50 Hz/VAC]	~1 / 230	~1 / 230	~3 / 400	~3 / 400	~3 / 400	~3 / 400
power / current	[kW/A]	0,37 / 1,65	0,75 / 3,9	1,25 / 2,1	1,5 / 2,6	2,8 / 4,4	2,8 / 4,4
speed	[min ⁻¹]	2010	1700	1400	1230	1230	1230
control input	[VDC]	0-10	0-10	0-10	0-10	0-10	0-10
protection class		IP54	IP54	IP54	IP54	IP54	IP54
wiring diagram		#15	#14	#14	#14	#14	#14

VKAP 3.0		100 LD	100 MD	125 LD	125 MD	150 LD	160LD	160 MD	200 LD
phase/voltage	[50 Hz/VAC]	~1 / 230	~1 / 230	~1 / 230	~1 / 230	~1 / 230	~1 / 230	~1 / 230	~1 / 230
power/current	[kW/A]	0,07 / 0,3	0,05 / 0,2	0,07 / 0,3	0,05 / 0,2	0,1 / 0,5	0,1 / 0,5	0,08 / 0,3	0,14 / 0,6
speed	[min ⁻¹]	2800	2750	2800	2750	2796	2796	2800	2659
capacitor	[μF]	2	4	2	4	2	2	2	4
protection class		IP44	IP44	IP44	IP44	IP44	IP44	IP44	IP44
wiring diagram		#16	#17	#16	#17	#16	#16	#16	#16

VKAP 3.0		200 MD	250 LD	250 MD	315 LD	315 MD
phase/voltage	[50 Hz/VAC]	~1 / 230	~1 / 230	~1 / 230	~1 / 230	~1 / 230
power/current	[kW/A]	0,1 / 0,5	0,14 / 0,6	0,14 / 0,6	0,28 / 1,2	0,22 / 0,9
speed	[min ⁻¹]	2796	2659	2659	2762	2704
capacitor	[μF]	2	4	2	5	5
protection class		IP44	IP44	IP44	IP44	IP44
wiring diagram		#16	#16	#16	#16	#16

VKA EKO		125	150	160	200	250	315
phase/voltage	[50 Hz/VAC]	~1 / 230	~1 / 230	~1 / 230	~1 / 230	~1 / 230	~1 / 230
power/current	[kW/A]	0,08 / 0,75	0,09 / 0,7	0,08 / 0,75	0,17 / 1,4	0,17 / 1,4	0,17 / 1,4
speed	[min ⁻¹]	3200	2550	3200	3230	3230	2510
control input	[VDC]	0-10	0-10	0-10	0-10	0-10	0-10
protection class		IP54	IP54	IP54	IP54	IP54	IP54
wiring diagram		#2	#2	#2	#2	#2	#2

VKS / VKSA		400-200-4 L1	400-200-4 L3	500-250-4 L1	500-250-4 L3	500-300-4 L1	500-300-4 L3	600-300-4 L1	600-300-4 L3
phase/voltage	[50 Hz/VAC]	~1 / 230	~3 / 400	~1 / 230	~3 / 400	~1 / 230	~3 / 400	~1 / 230	~3 / 400
power/current	[kW/A]	0,29 / 1,45	0,31 / 0,51	0,51 / 2,3	0,56 / 0,95	0,69 / 3	0,93 / 1,9	1,15 / 5,1	1,5 / 2,6
speed	[min ⁻¹]	1260	1230	1250	1270	1190	1380	1210	1310
capacitor	[μF]	5	-	8	-	10	-	16	-
protection class		IP44	IP44	IP54	IP54	IP54	IP54	IP54	IP54
wiring diagram		#7	#18*	#7	#18*	#7	#18*	#7	#18*

VKS / VKSA		600-350-4 L1	600-350-4 L3	700-400-4 L3	800-500-6 L3
phase/voltage	[50 Hz/VAC]	~1 / 230	~3 / 400	~3 / 400	~3 / 400
power/current	[kW/A]	2,4 / 11	2,5 / 7,4	3,7 / 6	2,7 / 4,9
speed	[min ⁻¹]	1340	1300	1320	830
capacitor	[μF]	35	-	-	-
protection class		IP54	IP54	IP54	IP54
wiring diagram		#7	#18*	#18*	#18*

VKS		800-500-4 L3	1000-500-4 L3
phase/voltage	[50 Hz/VAC]	~3 / 400	~3 / 400
power/current	[kW/A]	5 / 8,1	5 / 8,1
speed	[min ⁻¹]	1330	1330
capacitor	[μF]	-	-
protection class		IP54	IP44
wiring diagram		#18*	#18*

VKSA		500-300-6 L1	600-300-6 L1
phase/voltage	[50 Hz/VAC]	~1 / 230	~1 / 230
power/current	[kW/A]	0,26 / 1,15	0,4 / 1,8
speed	[min ⁻¹]	790	700
capacitor	[μF]	8	12
protection class		IP54	IP54
wiring diagram		#19	#7

VSA 3.0		190 S	190 L	220 S	220 M	225 L	250 L
phase/voltage	[50 Hz/VAC]	~1 / 230	~1 / 230	~1 / 230	~1 / 230	~1 / 230	~1 / 230
power/current	[kW/A]	0,05 / 0,2	0,07 / 0,3	0,07 / 0,28	0,1 / 0,5	0,14 / 0,6	0,22 / 0,9
speed	[min ⁻¹]	2750	2800	2600	2796	2659	2704
capacitor	[μF]	4	2	4	2	4	5
protection class		IP44	IP44	IP44	IP44	IP44	IP44
wiring diagram		#17	#16	#17	#16	#17	#16

VSA EKO		190	220	225	250
phase/voltage	[50 Hz/VAC]	~1 / 230	~1 / 230	~1 / 230	~1 / 230
power/current	[kW/A]	0,08 / 0,75	0,12 / 1,1	0,17 / 1,4	0,38 / 2,5
speed	[min ⁻¹]	3200	2790	3230	3370
control input	[VDC]	0-10	0-10	0-10	0-10
protection class		IP54	IP54	IP54	IP54
wiring diagram		#2	#2	#2	#3

VSV		250-2SL1
phase/voltage	[50 Hz/VAC]	~1 / 230
power/current	[kW/A]	0,22 / 0,9
speed	[min ⁻¹]	2704
capacitor	[μF]	5
protection class		IP44
wiring diagram		#16

VSV / VSVI / VSVI AL		311-4 L1	311-4 L3	355-4 L1	355-4 L3	400-4 L1	400-4 L3	450-4 L1	450-4 L3
phase/voltage	[50 Hz/VAC]	~1 / 230	~3 / 400	~1 / 230	~3 / 400	~1 / 230	~3 / 400	~1 / 230	~3 / 400
power/current	[kW/A]	0,17 / 0,7	0,15 / 0,35	0,3 / 1,27	0,24 / 0,44	0,54 / 2,3	0,44 / 0,77	0,89 / 3,8	0,65 / 1,1
speed	[min ⁻¹]	1333	1370	1428	1340	1357	1320	1348	1353
capacitor	[μF]	4	-	7	-	12	-	20	-
protection class		IP44	IP44	IP44	IP54	IP44	IP54	IP54	IP54
wiring diagram		#20	#18*	#20	#18*	#19	#18*	#20	#21*

VSV / VSVI / VSVI AL		500-4 L3	560-4 L3	630-4 L3	630-6 L3
phase/voltage	[50 Hz/VAC]	~3 / 400	~3 / 400	~3 / 400	~3 / 400
power/current	[kW/A]	1,25 / 2,8	1,47 / 2,4	3,9 / 6,6	1,15 / 2,5
speed	[min ⁻¹]	1360	1355	1360	880
protection class		IP54	IP54	IP54	IP54
wiring diagram		#18*	#22*	#18*	#18*

VSV EKO AL / VSVI EKO AL		311-L1	355-L1	400-L1	450-L3	500-L3	560-L3	630-L3
phase/voltage	[50 Hz/VAC]	~1 / 230	~1 / 230	~1 / 230	~3 / 400	~3 / 400	~3 / 400	~3 / 400
power/current	[kW/A]	0,36 / 1,51	0,37 / 1,61	0,75 / 3,5	1,45 / 2,22	1,25 / 2,02	1,5 / 2,51	2,8 / 4,4
speed	[min ⁻¹]	2450	2010	1700	1800	1400	1230	1230
control input	[VDC]	0-10	0-10	0-10	0-10	0-10	0-10	0-10
protection class		IP54	IP54	IP54	IP54	IP54	IP54	IP54
wiring diagram		#15	#15	#14	#14	#14	#14	#14

VSVI EKO AL CPG		311-L1	355-L1	400-L1	450-L3	500-L3	560-L3	630-L3
phase/voltage	[50 Hz/VAC]	~1 / 230	~1 / 230	~1 / 230	~3 / 400	~3 / 400	~3 / 400	~3 / 400
power/current	[kW/A]	0,36 / 1,51	0,37 / 1,61	0,75 / 3,5	1,45 / 2,22	1,25 / 2,02	1,5 / 2,51	2,8 / 4,4
speed	[min ⁻¹]	2450	2010	1700	1800	1400	1230	1230
control input	[VDC]	0-10	0-10	0-10	0-10	0-10	0-10	0-10
protection class		IP54	IP54	IP54	IP54	IP54	IP54	IP54
wiring diagram		#24	#24	#24	#23	#23	#23	#23

* The provided technical data is with 3x400V connection type. When 3x230V or 3x690V connection type is used, technical data will be different.



Not suitable for installation in living rooms: additional noise insulation required.

4.4. OPERATING CONDITIONS

	AKU / AKU EKO	KF T120 / KF T120 EC	KUB T120 / KUB EKO	VKAP 3.0 / VKA EKO	VKS / VKSA	VSA / VSA EKO	VSV / VSV EKO AL	VSVI / VSVI EKO AL
Minimum outdoor air temperature	-23 °C	-23 °C	-23 °C	-23 °C	-23 °C	-23 °C	-23 °C	-23 °C
Maximum outdoor air temperature	+40 °C	+40 °C	+40 °C	+40 °C	+40 °C	+40 °C	+40 °C	+40 °C
Minimum ambient air temperature	+5 °C	+5 °C	+5 °C	+5 °C	+5 °C	+5 °C	+5 °C	+5 °C
Maximum ambient air temperature	+40 °C	+40 °C	+40 °C	+40 °C	+40 °C	+40 °C	+40 °C	+40 °C
Installation	indoor	indoor/ outdoor	indoor/ outdoor	indoor	indoor	outdoor	outdoor	outdoor

4.5. STANDARD PACKAGE OF COMPONENTS

	AKU / AKU EKO	KF T120 / KF T120 EC	KUB T120 / KUB EKO	VKAP 3.0 / VKA EKO	VKS / VKSA	VSA / VSA EKO	VSV / VSV EKO AL	VSVI / VSVI EKO AL
Antivibration feet TS 25-30 M8 2530MFB20-55BF	-	4	-	-	-	-	-	-
Nut 8 DIN934	-	4	-	-	-	-	-	-
Spring washer 8 DIN127	-	4	-	-	-	-	-	-
Nylon cable tie 2,5x100	-	1	-	-	-	-	-	-
Bracket LAV	-	-	-	1	-	-	-	-
Drilling screw 4,2x13 DIN7504M	-	-	-	4	-	-	-	-
Manual	1	1	1	1	1	1	1	1

4.6. DESCRIPTION OF COMPONENTS

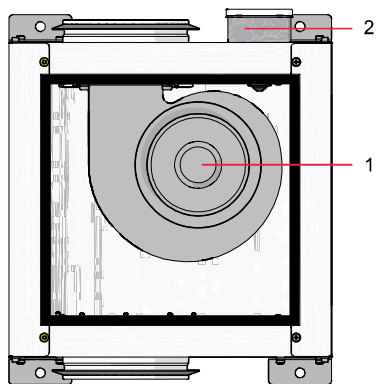

Fig. 4.6.1 AKU / AKU EKO

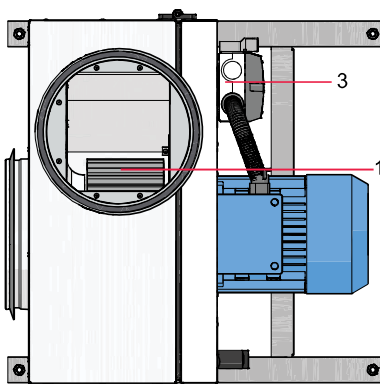

Fig. 4.6.2 KF T120

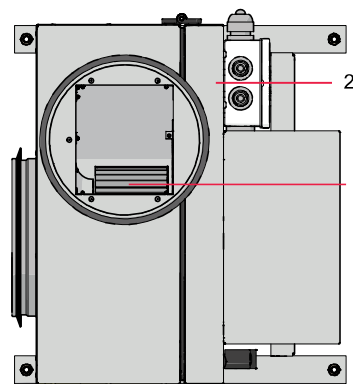

Fig. 4.6.3 KF T120 EC

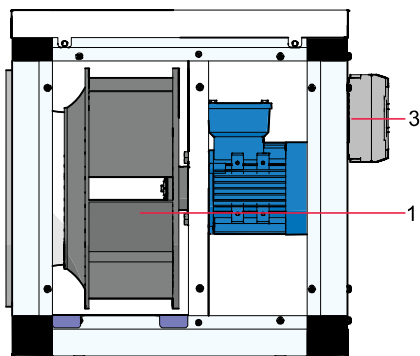

Fig. 4.6.4 KUB T120

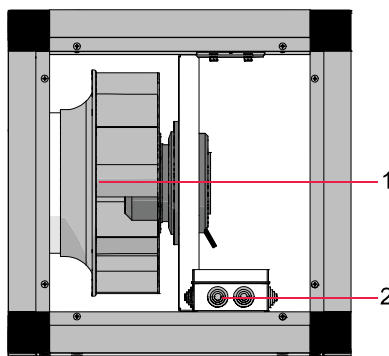

Fig. 4.6.5 KUB EKO

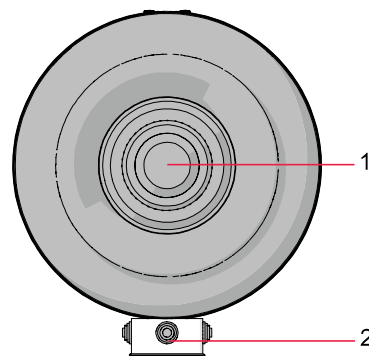

Fig. 4.6.6 VKAP 3.0 / VKA EKO

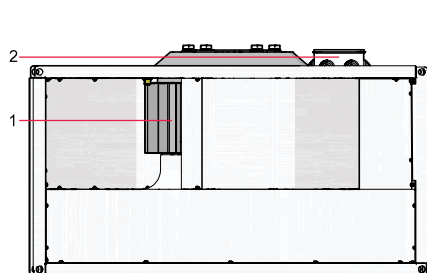

Fig. 4.6.7 VKS

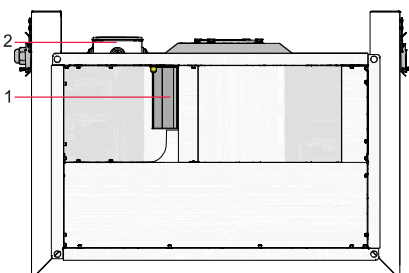

Fig. 4.6.8 VKSA

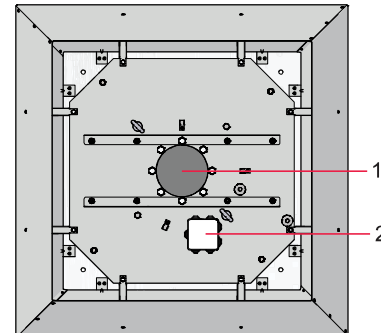

Fig. 4.6.9 VSV / VSVI

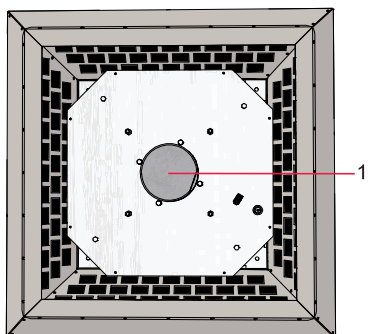

Fig. 4.6.10 VSV EKO / VSVI EKO

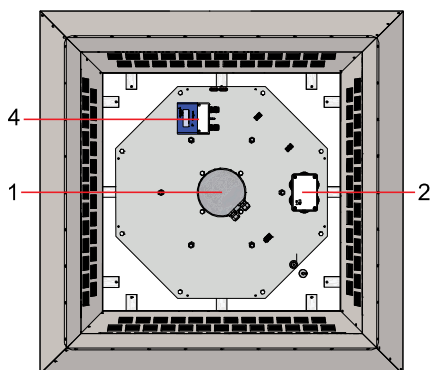

Fig. 4.6.11 VSVI EKO AL CPG

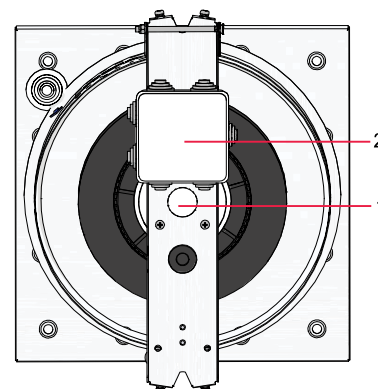

Fig. 4.6.12 VSA 3.0 / VSA EKO

1 - Fan; 2 - Electrical connection box; 3 - Main switch; 4 - Pressure transmitter.

5. INSTALLATION

5.1. RECEPTION OF GOODS

Each device is carefully checked before transportation. When receiving the goods, checking the devices for any damage made during transportation is recommended. If any damage to the unit is observed, immediately contact the representatives of a transport company. Please inform the representative of the manufacturer, if any deviation of the device is noticed.

5.2. TRANSPORTATION AND STORAGE

- All units are factory-packaged to withstand normal conditions of transportation.
- When unpacking, check the unit for any damage made during transportation. Installing the damaged units is not allowed!
- The packaging is used for protection purposes only!
- When unloading and storing the units, use suitable lifting equipment to avoid damage and injuries. Do not lift units by holding on power supply cables, connection boxes, air extract or exhaust flanges. Avoid hits and shock overloads. Before installation, the units must be stored in a dry room with relative air humidity not exceeding 70 % (at +20 °C) and with an average ambient temperature ranging between +5 °C and +30 °C. The storage place must be protected against dirt and water.
- The units must be transported to the storage place or installation site using forklifts.
- The recommended storage period should not be longer than one year. In case of storing the units for a period longer than one year, checking if the fan bearings and motor rotate without difficulty (turning the impeller by hand) and if the electric circuit insulation is not damaged or the moisture has not accumulated must be performed before the installation of the unit.

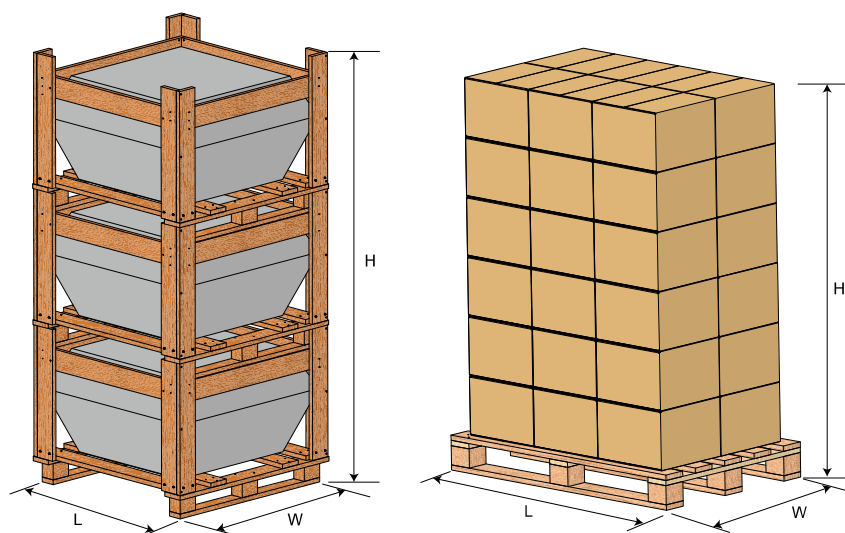

	Dimensions of a single package			Dimensions of a multi-package			Max. number of transported packages [PCS.]
	H1 [mm]	W1 [mm]	L1 [mm]	H2 [mm]	W2 [mm]	L2 [mm]	
AKU 125	305	420	495	1900	800	1200	20
AKU 160	305	420	495	1900	800	1200	20
AKU 200 D	305	420	495	-	-	-	1
AKU 200 M	425	455	535	1900	900	1200	16
AKU 250 D	780	900	765	-	-	-	1
AKU 250 M	425	455	535	-	-	-	1
AKU 250 S	780	890	765	-	-	-	1
AKU 315 D	850	1050	900	-	-	-	1
AKU 315 M	780	890	765	-	-	-	1
AKU 400 D	850	1050	900	-	-	-	1
AKU 400 S	962	832	957	-	-	-	1
AKU EKO 125	330	420	500	1900	800	1200	16
AKU EKO 160	345	495	650	1900	800	1200	9
AKU EKO 200	430	555	705	2000	800	1200	8
AKU EKO 250	430	555	705	2000	800	1200	8
AKU EKO 315	760	630	660	-	-	-	1
AKU EKO 700X400	855	1070	840	-	-	-	1
KF T120 160-4 L3	740	540	550	-	-	-	1
KF T120 180-4 L3	740	540	550	-	-	-	1
KF T120 200-4 L3	740	540	550	-	-	-	1
KF T120 225-4 L3	850	600	650	-	-	-	1

	Dimensions of a single package			Dimensions of a multi-package			Max. number of transported packages
	H1	W1	L1	H2	W2	L2	[PCS.]
	[mm]	[mm]	[mm]	[mm]	[mm]	[mm]	
KF T120 250-4 L3	950	800	800	-	-	-	1
KF T120 280-4 L3	940	780	800	-	-	-	1
KF T120 315-4 L3	940	780	800	-	-	-	1
KF T120 355-4 L3	1130	765	865	-	-	-	1
KF T120 400-4 L3	1130	765	865	-	-	-	1
KF T120 EC F 160	740	540	550	-	-	-	1
KF T120 EC F 180	740	540	550	-	-	-	1
KF T120 EC F 200	770	575	580	-	-	-	1
KF T120 EC F 250	940	780	800	-	-	-	1
KF T120 EC F 280	940	780	800	-	-	-	1
KF T120 EC B 315	975	785	765	-	-	-	1
KF T120 EC B 355	1130	865	765	-	-	-	1
KF T120 EC B 400	1130	865	765	-	-	-	1
KUB T120 355-4 L3	900	600	600	-	-	-	1
KUB T120 400-4 L3	1035	765	765	-	-	-	1
KUB T120 450-4 L3	1050	800	800	-	-	-	1
KUB T120 500-4 L3	1050	800	800	-	-	-	1
KUB T120 560-4 L3	1200	950	950	-	-	-	1
KUB T120 630-4 L3	1250	970	970	-	-	-	1
KUB EKO 50-355	900	600	600	-	-	-	1
KUB EKO 67-400	1035	765	765	-	-	-	1
KUB EKO 67-500	1050	800	800	-	-	-	1
KUB EKO 80-560	1200	900	900	-	-	-	1
KUB EKO 80-630	1170	900	900	-	-	-	1
KUB EKO 100-630	1300	1150	1150	-	-	-	1
VKAP 3.0 100	230	260	300	1900	800	1200	72
VKAP 3.0 125	230	260	300	1900	800	1200	72
VKAP 3.0 150	260	360	400	1800	800	1200	36
VKAP 3.0 160 LD	260	360	400	1900	800	1200	36
VKAP 3.0 160 MD	260	360	400	1900	800	1200	72
VKAP 3.0 200	260	360	400	1900	800	1200	36
VKAP 3.0 250	260	360	400	1900	800	1200	36
VKAP 3.0 315	270	410	410	2100	850	1260	42
VKA EKO 125	230	260	300	2200	800	1200	96
VKA EKO 160	230	260	300	2200	800	1200	96
VKA EKO 200	260	360	400	400	900	1200	42
VKA EKO 250	260	360	400	2100	800	1200	42
VKA EKO 315	270	410	410	2200	850	1260	42
VKS 400-200	270	460	460	-	-	-	1
VKS 500-250	330	560	570	-	-	-	1
VKS 500-300	370	560	580	-	-	-	1
VKS 600-300	650	800	850	-	-	-	1
VKS 600-350	700	750	850	-	-	-	1
VKS 700-400	750	870	850	-	-	-	1
VKS 800-500-4 L3	850	950	910	-	-	-	1
VKS 800-500-6 L3	720	950	910	-	-	-	1
VKS 1000-500	540	1040	980	-	-	-	1
VKSA 400-200-4 L1	375	485	625	-	-	-	1
VKSA 400-200-4 L3	375	485	625	2200	800	1200	16
VKSA 500-250	740	540	550	-	-	-	1
VKSA 500-300	460	600	720	-	-	-	1
VKSA 600-300	742	825	760	-	-	-	1
VKSA 600-350	742	825	820	-	-	-	1
VKSA 700-400	852	940	850	-	-	-	1
VKSA 800-500	950	950	1050	-	-	-	1

	Dimensions of a single package			Dimensions of a multi-package			Max. number of transported packages
	H1	W1	L1	H2	W2	L2	
	[mm]	[mm]	[mm]	[mm]	[mm]	[mm]	[PCS.]
VSA 190	350	235	350	1900	800	1200	42
VSA 220	460	235	460	1900	800	1200	18
VSA 225	460	260	460	2200	800	1200	16
VSA 250	460	260	460	1900	800	1200	24
VSA 190 EKO	350	235	350	2200	800	1200	6
VSA 220 EKO	460	260	460	500	900	1200	4
VSA 225 EKO	460	260	460	2200	800	1200	16
VSA 250 EKO	460	325	460	500	900	1200	4
VSV 250-2SL1	330	450	450	-	-	-	1
VSV 311	620	620	620	1700	800	1200	4
VSV 355-4 L1	700	800	800	-	-	-	1
VSV 355-4 L3	690	790	790	-	-	-	1
VSV 400	750	800	800	-	-	-	1
VSV 450	755	970	970	-	-	-	1
VSV 500	755	970	970	-	-	-	1
VSV 560	870	1225	1225	-	-	-	1
VSV 630	870	1225	1225	-	-	-	1
VSV EKO AL 311	620	620	620	-	-	-	1
VSV EKO AL 355	690	790	790	-	-	-	1
VSV EKO AL 400	690	790	790	-	-	-	1
VSV EKO AL 450	755	970	970	-	-	-	1
VSV EKO AL 500	755	970	970	-	-	-	1
VSV EKO AL 560	870	1225	1225	-	-	-	1
VSV EKO AL 630	870	1225	1225	-	-	-	1
VSVI 311	394	718	776	-	-	-	4
VSVI 355	682	905	905	-	-	-	1
VSVI 400	682	905	905	-	-	-	1
VSVI 450	745	1030	1030	-	-	-	1
VSVI 500	980	1030	1030	-	-	-	1
VSVI 560	870	1330	1330	-	-	-	1
VSVI 630	865	1325	1325	-	-	-	1
VSVI AL 311	627	735	735	-	-	-	1
VSVI AL 355	682	905	905	-	-	-	1
VSVI AL 400	682	905	905	-	-	-	1
VSVI AL 450	750	1030	1030	-	-	-	1
VSVI AL 500	780	1030	1030	-	-	-	1
VSVI AL 560	870	1330	1330	-	-	-	1
VSVI AL 630-L3	865	1325	1325	-	-	-	1
VSVI EKO AL 311	650	750	750	-	-	-	1
VSVI EKO AL 355	682	905	905	-	-	-	1
VSVI EKO AL 400	700	920	920	-	-	-	1
VSVI EKO AL 450	750	1030	1030	-	-	-	1
VSVI EKO AL 500	980	1030	1030	-	-	-	1
VSVI EKO AL 560	870	1330	1330	-	-	-	1
VSVI EKO AL 630	870	1330	1330	-	-	-	1

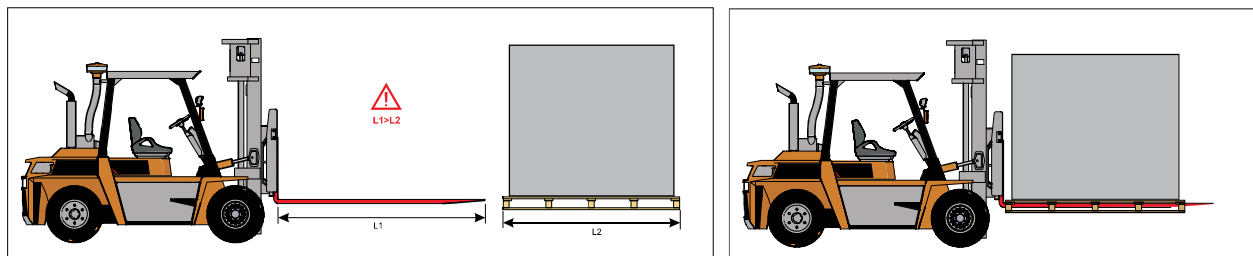

Fig. 5.2.1 Lifting by forklift.

⚠ To prevent damage to the casing, only a product placed on a pallet should be lifted.

5.3. UNPACKING

⚠ Accessories may be packed together with the product. Prior to transporting the unit, the accessories should be unpacked first.

- After unpacking the unit, examine it to make sure that no damage was made during transportation. Installation of damaged units is not allowed!
- Before commencing the installation of the unit, please check if all ordered equipment has been delivered. Any deviation from the ordered equipment list must be reported to the product supplier.

5.4. PIPING AND INSTRUMENTATION DIAGRAM

Availability and location of exact accessories provided as components in the diagrams may depend on fan unit model or installation purpose of the unit. When air is supplied to the premises, air flow outlet should be connected to the premises and air damper should be connected to the air flow inlet side. When air is extracted from the premises, air flow inlet should be connected to the premises and air damper should be connected to the air flow outlet side.

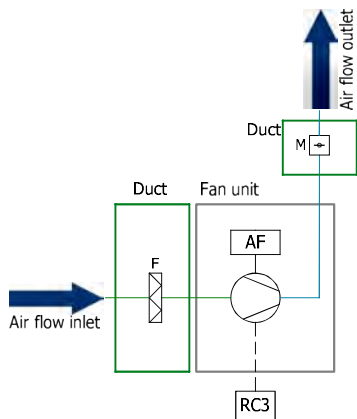

Fig. 5.4.1 KF T120, KF T120 EC, KUB T120 fans

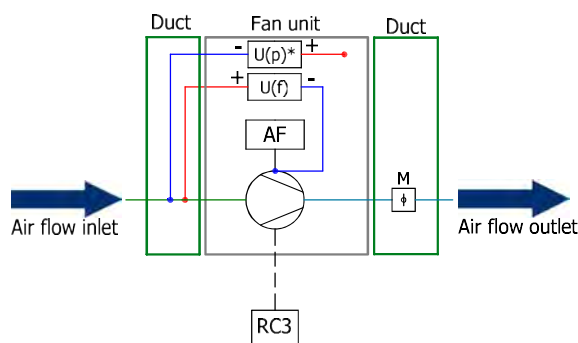

Fig. 5.4.2 VSVI EKO AL CPG fans

* U(p) is converted from U(f) to control fan speed by air flow

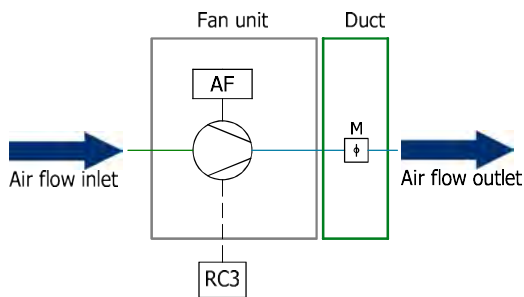

Fig. 5.4.3 VSA, VSA EKO, VSV, VSVI, VSVI AL, VSV EKO AL, VSVI EKO AL, KUB EKO fans

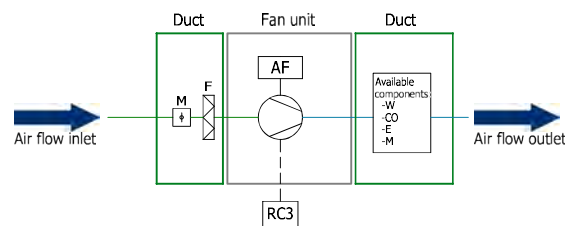

Fig. 5.4.4 AKU, AKU EKO, VKAP 3.0, VKA EKO, VKS, VKSA fans

LIST OF INTEGRATED COMPONENTS

AF	Air fan
U(f)	Air pressure controller

LIST OF OPTIONAL ACCESSORIES

F	Air filter
RC3	Fan speed controller
W	Water heater
CO	Water cooler
E	Electrical heater
M	Air damper
U(p)*	Air flow controller

* U(p) is converted from U(f) to control fan speed by air flow.

For additional inputs / outputs of the exact fan unit, see section **"ELECTRICAL WIRING DIAGRAMS"**.

5.5. MOUNTING



The protective film is used to protect the unit during transportation. It is recommended to remove the film; otherwise, oxidation signs may occur.

GENERAL REQUIREMENTS

- Installation works should be carried out by qualified and trained staff only.
- These fans are not designed for operating in rooms with explosive gas, grinding dust, soot, flour, etc.
- Before connecting to the air duct system, the connection openings of the ventilation system air ducts should be closed.
- Protection against contact with the impeller of the operating fan should be ensured (special accessories are used for this reason, or an appropriate length of air duct is selected).
- Do not connect the elbows close to the connection flanges of the unit. The minimum distance of the straight air duct between the unit and the first branch of the air duct in the suction air duct must be $1xD$, in the air exhaust duct $3xD$, where D is the diameter of the air duct. For rectangular air ducts: $D = \sqrt{4xBxH/\pi}$
where B – width of the air duct and H – height of the air duct.
- When connecting air ducts, consider the direction of air flow indicated on the casing of the unit.
- It is recommended to use accessories – clamps for connection of the fan into the air duct system. This will reduce the vibration transmitted by the unit to the air duct system and environment.
- It is recommended to use flexible connections in order to reduce vibration in the air duct system.
- Installation shall be performed in such a manner that the weight of the air duct system and its components does not overload the ventilation unit.
- If the air duct system becomes unstable because of the fan weight, the fan must be additionally fixed to the floor, wall, or ceiling.
- When mounting the fans onto the walls or ceilings, it is recommended to use special supporting accessories.
- It is recommended to use air filters or grease filters to reduce the accumulation of dirt on the fan impeller. The accumulated dirt misbalances the impeller and causes vibrations. This may be the cause of the fan's motor failure.
- If the installed fan is near the wall, it may transmit noise vibrations to the premises. Though the level of noise generated by the fans is admissible, we recommend mounting the unit at a distance of 400 mm from the nearest wall. Where this is not possible, we recommend mounting the unit on the wall of the room where the level of noise is not significant.
- In addition, vibrations may also be transmitted through the floor and ceiling. If possible, the floor and ceiling shall be additionally insulated in order to suppress the noise.
- If there is a possibility for condensate or water to access the unit, external protective measures should be installed.
- To ensure safe operation, check that the fan, installed parts and accessories are firmly and tightly installed.
- During installation, enough space must be retained for opening and cleaning the impeller.



IMPORTANT. The fan should be installed only in such a way that the entire surface of the fan fully adheres to the surface of the installation.

AKU / AKU EKO

- The fan can be installed on the wall, floor or ceiling. Four (4) fastening screws are supplied for this purpose.
- Inappropriate fan installation is shown in Fig. 5.5.3.
- If there is not enough space, the maintenance door may be removed.
- If necessary, the option to change the opening side of the fan maintenance doors is provided.

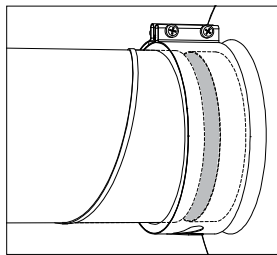

Fig. 5.5.1 Clamp mounting

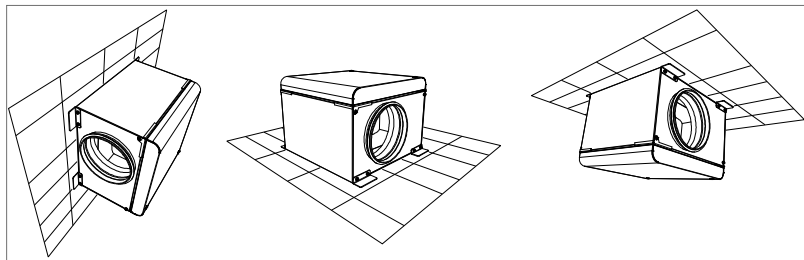

Fig. 5.5.2 Installation on the wall, floor or ceiling

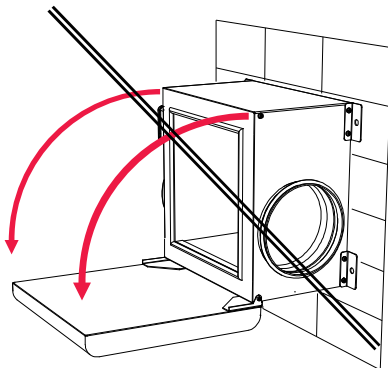

Fig. 5.5.3 Inappropriate fan installation

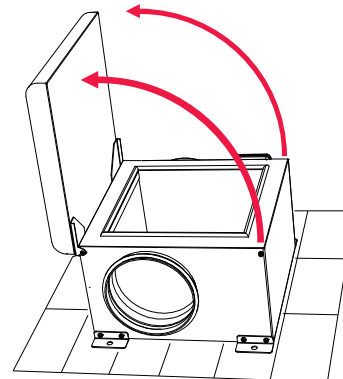

Fig. 5.5.4 Enough space should be retained for the opening of the fan maintenance door.

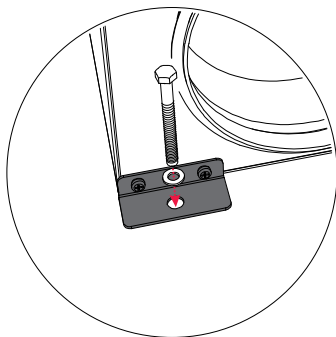

Fig. 5.5.5 Mounting

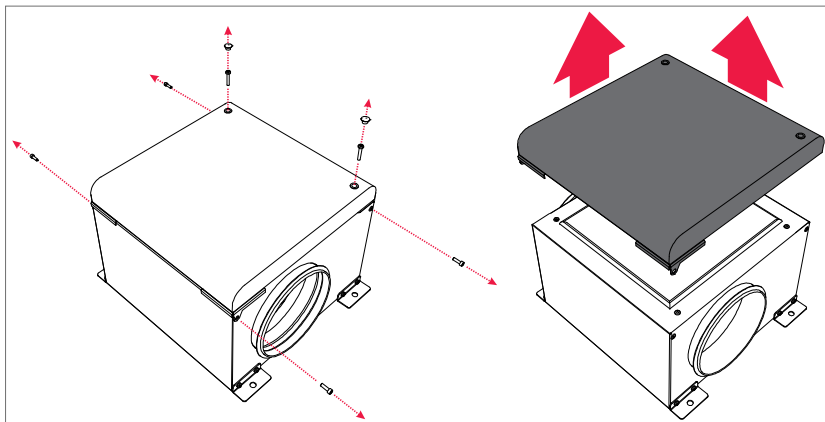

Fig. 5.5.6 Maintenance door removal

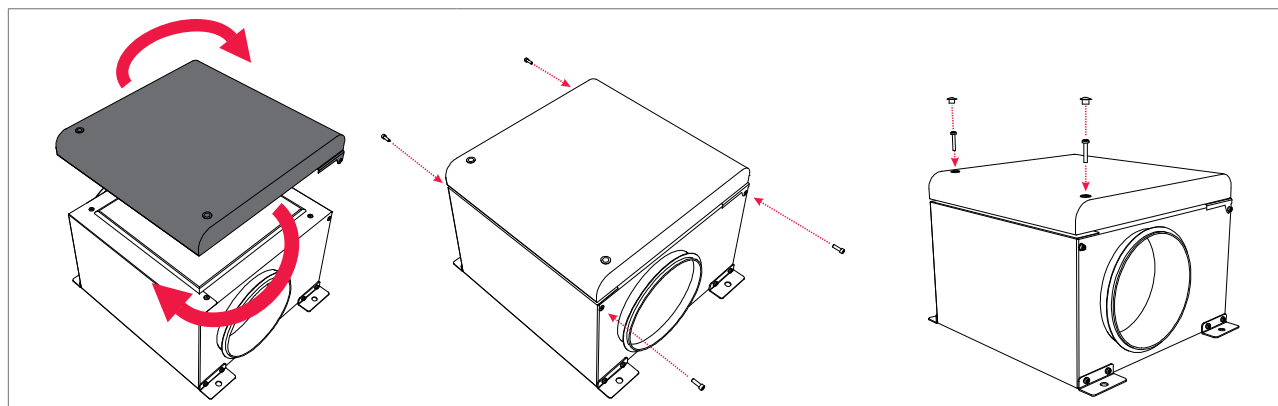
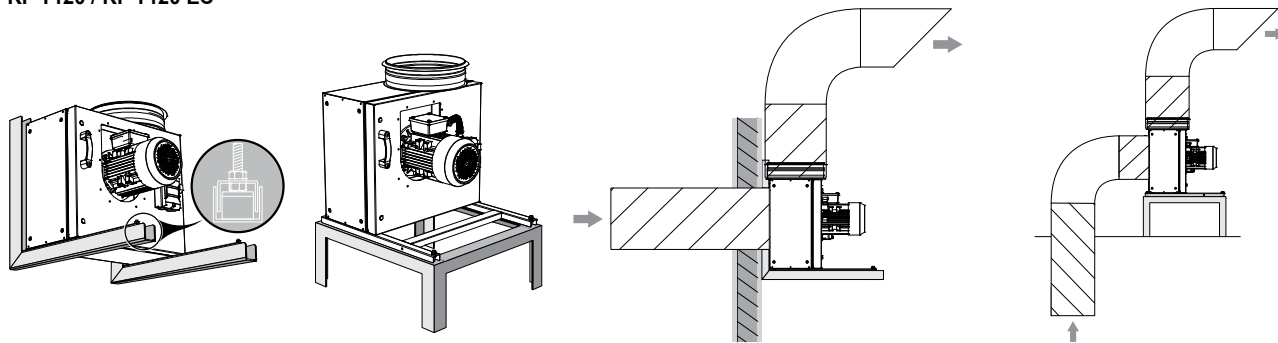

Fig. 5.5.7 Changing the fan's maintenance door side

KF T120 / KF T120 EC



KUB T120 / KUB EKO

- We recommend using a vibration isolating gasket.
- The fan is connected to the air ducts using screws or C profile.
- If necessary, the maintenance side can be changed. If the maintenance side is changed, the removable grease tray should be turned 180°.



Fig. 5.5.8 Changing the maintenance side

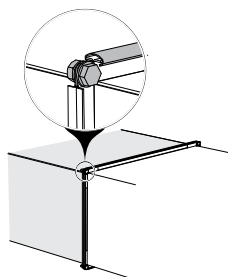

Fig. 5.5.9 Vibration isolating gasket

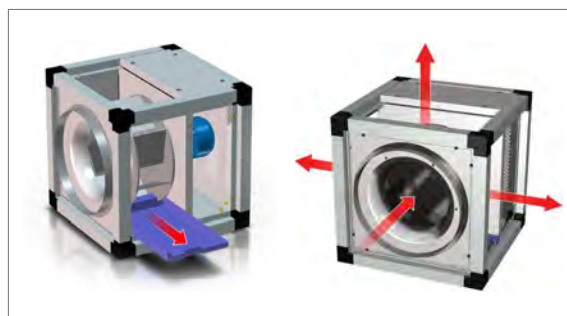

Fig. 5.5.10 When connecting air ducts, consider the direction of air flow indicated on the casing of the unit.

VKAP 3.0 / VKA EKO

- The fan can be mounted in any position.

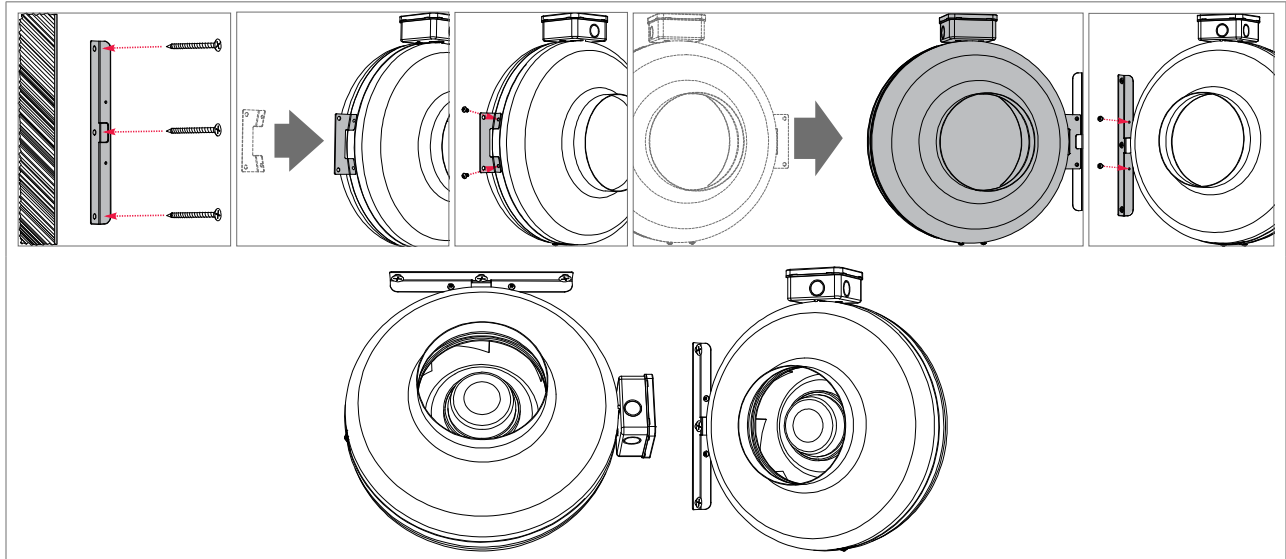

Fig. 5.5.11 Mounting the device onto the wall using the supporting element

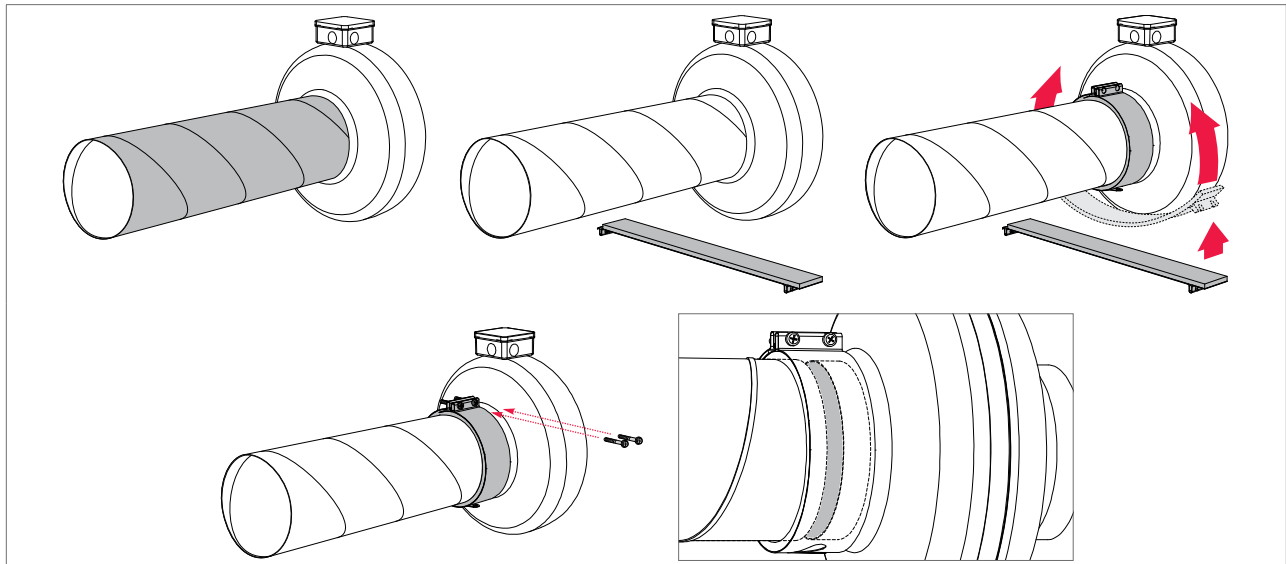

Fig. 5.5.12 Connection to the duct using the clamp

VKS / VKSA

- The fan can be installed vertically or horizontally.
- The fan is connected to the air ducts using bolts and a C profile.
- Rectangular duct fans are mounted into rectangular ducts in ventilation systems. Single-phase and three-phase motors are ready-wired with thermo-contact leads and protectors. If a speed controller is used, a separate thermo-contact relay is not needed.
- When a fan is connected to the circular duct system, we recommend using special accessories – adaptors.

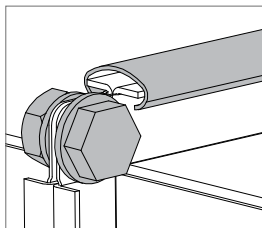

Fig. 5.5.13 Fan connection using bolts and a C profile

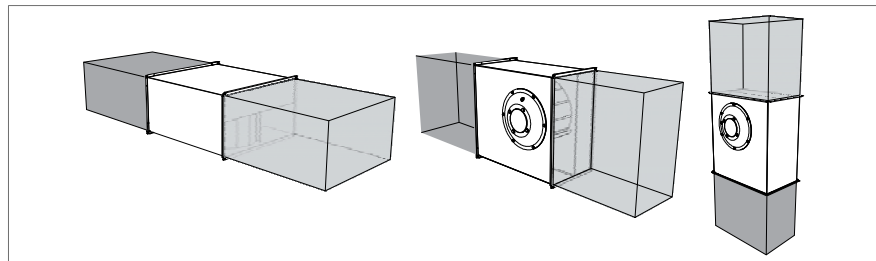

Fig. 5.5.14 The fan can be installed vertically or horizontally

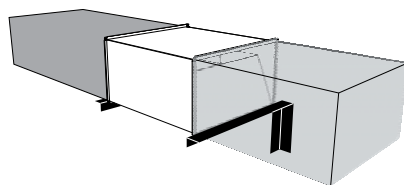

Fig. 5.5.15 Fixing the fan to the floor, wall or ceiling

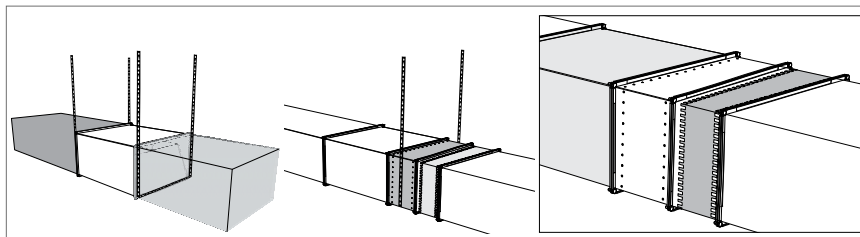

Fig. 5.5.16 Fan connection to the air duct system using accessories. If using flexible connections, the fan must be additionally fixed to the floor, wall or ceiling by using an additional air duct

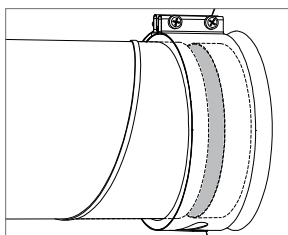

Fig. 5.5.17 Mounting using special accessories – adaptors

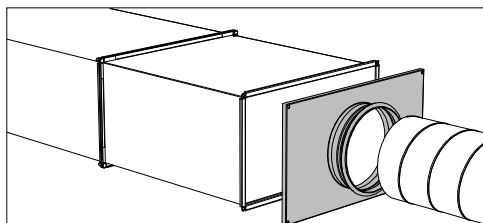

Fig. 5.5.18 Enough space must be retained for opening and cleaning the impeller

AIR DUCT CONNECTION

The following devices can be connected to pull the air directly from the ventilated room or from the air duct system.

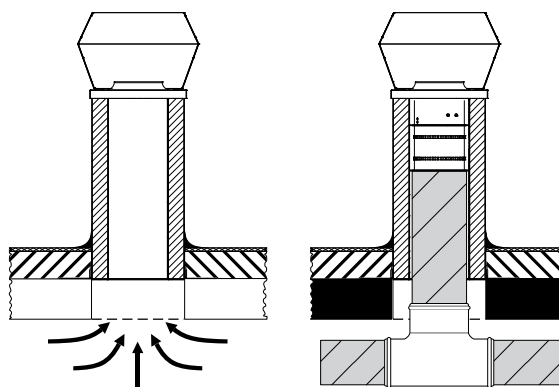

Fig. 5.5.19 Air duct connection

CHIMNEY INSTALLATION

- The chimney has to be mounted on the roof above the prepared chamber which cannot be greater than its own internal chamber.
- The chimney has to be firmly attached to the roof so that the later mounted fan will be in a horizontal position.
- The chimney must be covered with a heat-deterrent substance. Choose the isolating material with the most thermal resistance.
- Cover the roof coating.
- The chimney must be firmly attached to the roof.
- The space between the chimney and roof coating has to be sealed with waterproof material.

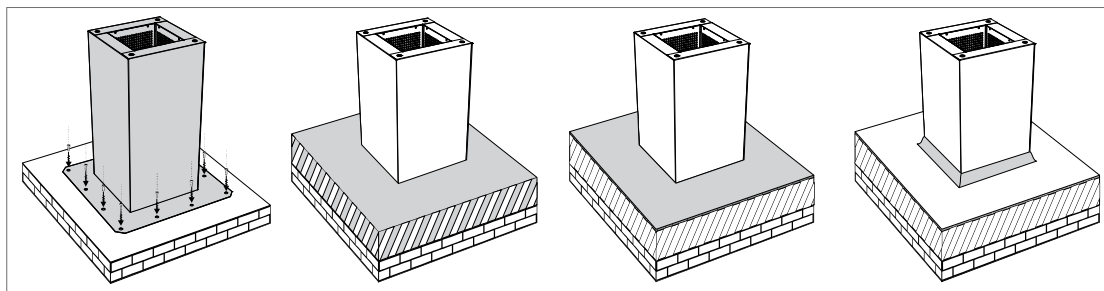

Fig. 5.5.20 Chimney installation

VSA 3.0 / VSA EKO

- The device is mounted onto the chimney using accessories: reverse thrust valves, flexible connectors, and connection flanges. They have to be installed only as shown in Fig. 5.5.21.
- The power supply cord has to be pushed through a plastic tube inside the chimney and connected to the fan.
- Attach the fan to the roof chimney.
- The roof fan is attached to the chimney using screws. It is necessary to use rubber gaskets.
- When the fan is attached to the chimney, put back the fan cover and screw it with four (4) screws.

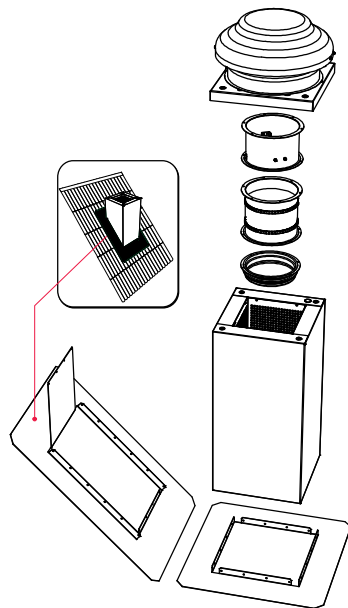

Fig. 5.5.21 Mounting and installation using accessories

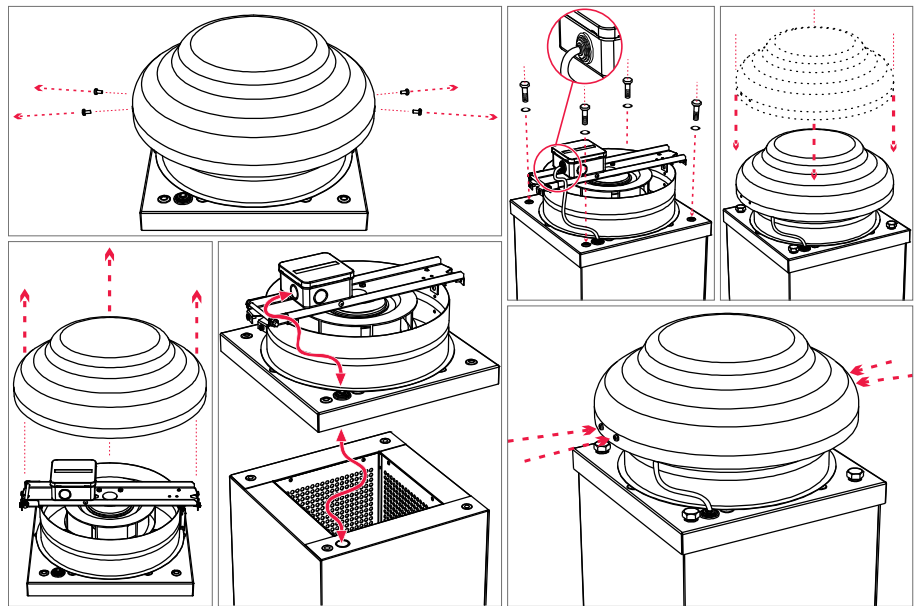

Fig. 5.5.22 Mounting

VSV / VSV EKO AL / VSVI EKO AL

- The device is mounted onto the chimney using accessories: reverse thrust valves, flexible connectors, and connection flanges. They have to be installed only as shown in Fig. 5.5.23.
- The power supply cord has to be pushed through a plastic tube inside the chimney.
- Attach the fan to the roof chimney.
- The roof fan is attached to the chimney using screws. It is necessary to use rubber gaskets.
- When the fan is attached to the chimney, put back the fan cover and screw it in with screws.

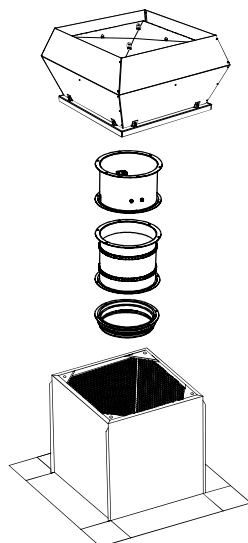

Fig. 5.5.23 Mounting and installation using accessories

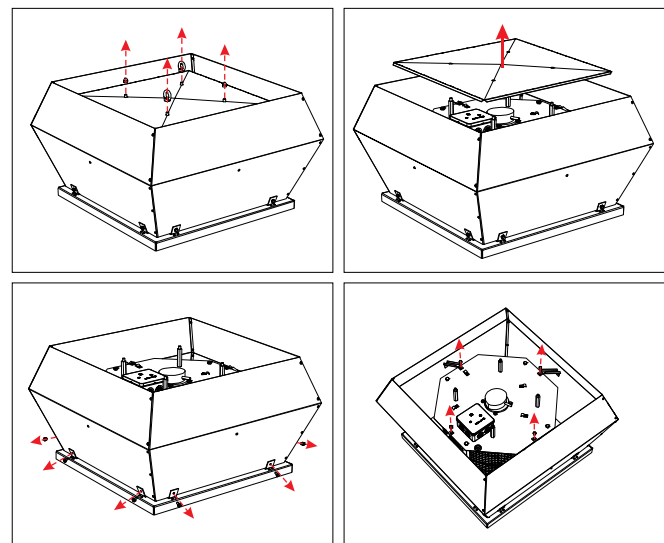

Fig. 5.5.24 Cover opening

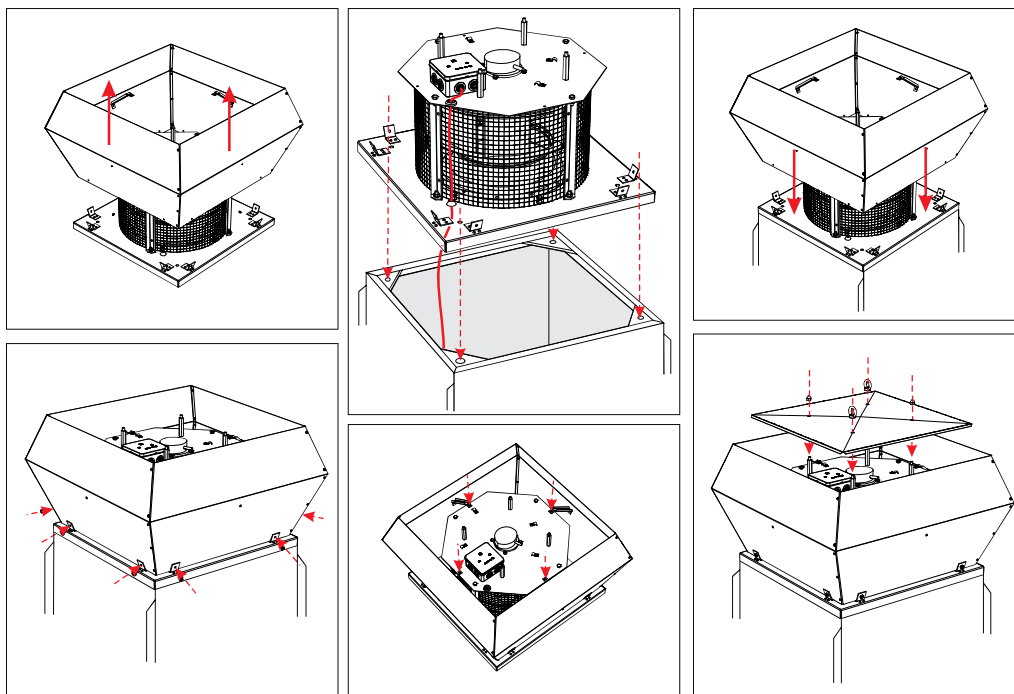

Fig. 5.5.25 Mounting

5.6. CONNECTION OF THE AIR DUCTS

- The connected air ducts must not be bent and must be fixed separately.
- Make sure that the fans may not be accessed through air duct heads. Otherwise, a protective grid should be installed. You may choose the grid from the range of products provided on our website <https://select.salda.it>.
- Do not reduce the diameter of the piping near the air inlet or exhaust ducts. If you want to reduce the airflow speed in the system, also to reduce pressure and noise level, you can increase the diameter.
- In order to reduce the level of noise in the air supply system, install silencers (see the chapter on air supply system installation).
- In order to reduce air loss in the system, the air ducts and profile components should be of class C or higher. The catalogue of the above-mentioned items can be found on our website <https://select.salda.it>.
- External air and exhaust system piping should be isolated in order to prevent heat loss and condensation.
- We recommend to maintain a distance of up to 8 meters between air intake and air exhaust ducts. The air intake point should be installed away from potential air pollution sources.
- When installing air ducts next to the ventilation equipment, brackets must be used. They suppress vibrations and assure secure installation of the various system parts. The necessary brackets can be found in our catalogue or on our website <https://select.salda.it>.
- Air ducts are often mistakenly connected in an inappropriate location. The ventilation units bear the labels indicating the correct air duct connection layout. Before starting up the system, carefully check if all related works have been performed properly.



For flange diameters see chapter "DIMENSIONS AND WEIGHT".

5.7. CONNECTION OF THE UNIT TO THE ELECTRIC NETWORK

- Supply voltage to the unit must be connected by a qualified specialist following the manufacturer's instructions and applicable safety guidelines.
- The unit's power network voltage must correspond to the electro-technical specifications of the unit indicated in the technical decal.
- The unit's voltage, power and other technical specifications are provided in the unit's technical decal (on the unit casing). The unit must be connected to the voltage plug socket of the grounded power network in accordance with the applicable requirements.
- The unit must be earthed according to electrical equipment installation regulations.
- Using extension wires (cables) and power network plug socket distribution devices is not allowed.
- Prior to carrying out any ventilation unit installation and connection works (before the unit is commissioned), the unit must be disconnected from the power network.
- After installation of the fan unit, the power network plug socket must be accessible at any time. If the unit is equipped with circuit breaker, disconnection from the power network is performed through the circuit breaker (by disconnecting phase poles and neutral).
- Before it is connected to the power network, the unit must be carefully checked for any damage (operation, control, and measurement nodes) made during transportation.
- The power cable can be replaced only by a qualified technician, after the evaluation of the rated power and current.
- For power connection of the exact fan unit, see section "**ELECTRICAL WIRING DIAGRAMS**".



The manufacturer does not assume any liability for personal injuries and property damage due to non-conformance with the provided instructions.

5.8. START-UP RECOMMENDATIONS

5.8.1. SYSTEM PROTECTION

Available protection signals depend on exact fan unit (see section **"ELECTRICAL WIRING DIAGRAMS"**). Some fans may have integrated thermal protection signal, fault signal, tacho output (for fan speed monitoring) or fan status indication signal. Signals can be connected to external ventilation system for control and status indication.

All units must be used with external protection device. Recommended protection device rating for each unit is provided in the table below.

AKU	125 D	125 M	160 D	160 M	200 D	200 M	250 D	250 M	250 S
Mains fuse	2A	1A	2A	2A	2A	2A	5A	2A	2A
AKU	315 D	315 M	400 D	400 S					
Mains fuse	16A	8A	16A	10A					
AKU EKO	125	160	200	250	315	700X400	700X400 S		
Mains fuse	1A	1,5A	2A	2A	4A	6A	8A		
KF T120 EC	B 315	B 355	B 400	F 160	F 180	F 200	F 250	F 280	
Mains fuse	2A	2A	5A	2A	2A	1A	5A	6A	
KF T120	160-4 L3	180-4 L3	200-4 L3	225-4 L3	250-4 L3	280-4 L3	315-4 L3	355-4 L3	400-4 L3
Mains fuse	2A	2A	3A	3A	5A	8A	2A	2A	3A
KUB T120	355-4L3	400-4L3	450-4L3	500-4L3	560-4L3	630-4L3			
Mains fuse	2A	3A	4A	5A	10A	16A			
KUB EKO	50-355	67-400	67-500	80-560	80-630	100-630			
Mains fuse	3A	6A	6A	4A	6A	8A			
VKAP 3.0	100 LD	100 MD	125 LD	125 MD	150 LD	160 LD	160 MD	200 LD	200 MD
Mains fuse	1A	1A	1A	1A	1,5A	1,5A	1A	1,5A	1,5A
VKAP 3.0	250 LD	250 MD	315 LD	315 MD					
Mains fuse	1,5A	1,5A	2A	2A					
VKA EKO	125	160	200	250	315				
Mains fuse	1,5A	1,5A	2A	2A	2A				
VKS / VKSA	400-200-4 L1	400-200-4 L3	500-250-4 L1	500-250-4 L3	500-300-4 L1	500-300-4 L3	500-300-6 L1	600-300-4 L1	600-300-4 L3
Mains fuse	3A	1,5A	4A	2A	5A	3A	3A	8A	4A
VKS / VKSA	600-300-6 L1	600-350-4 L1	600-350-4 L3	700-400-4 L3	800-500-4 L3	800-500-6 L3	1000-500-4 L3		
Mains fuse	4A	16A	12A	10A	12A	8A	12A		
VSA 3.0	190 S	190 L	220 S	220 M	225 L	250 L			
Mains fuse	1A	1A	1A	1,5A	1,5A	2A			
VSA EKO	190	220	225	250					
Mains fuse	1,5	2A	2A	4A					

VSV / VSVI / VSVI AL	250-2SL1	311-4 L1	311-4 L3	355-4 L1	355-4 L3	400-4 L1	400-4 L3	450-4 L1	450-4 L3
Mains fuse	2A	2A	1,5A	2A	1,5A	4A	2A	6A	2A

VSV / VSVI / VSVI AL	500-4 L3	560-4 L3	630-4 L3	630-6 L3
Mains fuse	4A	4A	10A	4A

VSV EKO AL / VSVI EKO AL / VSVI EKO AL CPG	311-L1	355-L1	400-L1	450-L3	500-L3	560-L3	630-L3
Mains fuse	3A	3A	5A	4A	3A	3A	6A

Protection devices with slow activation should be used for non EKO and non EC units, because initial current of AC fans is higher than nominal.



To ensure safe maintenance of the unit, it is necessary to turn off the main switch and/or external protection device.

5.8.2. PRE START-UP RECOMMENDATIONS OF THE UNIT (IN THE PRESENCE OF THE END-USER)

Prior to start-up, the system must be carefully cleaned. Check for the following:

- Operation systems and unit elements as well as electrical components were not damaged during installation,
- All electrical components are installed and connected to the power supply and fit for service,
- Cable connection comply with the existing wiring diagrams,
- All electrical equipment protection components are properly connected (if they are additionally used),
- Cables and wires correspond to all applicable safety and functional requirements, diameters, etc.,
- Earthing and protection systems are properly installed,
- Condition of all seals and sealing surfaces is proper.

6. MAINTENANCE

6.1. SAFETY INSTRUCTION



Unplug the unit from the mains before performing any other maintenance steps (disconnect the power plug from the outlet or in case a circuit breaker is installed, disconnect it as well. Make sure that it cannot be turned on by the third parties) and wait until the fan completely stops (for about 2 min.).

6.2. GENERAL RECOMMENDATIONS FOR THE MAINTENANCE OF VENTILATION SYSTEM

In order to ensure the proper functioning of the system, maintenance requirements and its periods should be observed. Otherwise, the warranty shall be void. Some recommendations are provided in the table below, but they are just advisory, as the need for system maintenance depends on the location of the unit installation, the pollution of the atmosphere, population, working hours, etc.

COMPONENT	DURING START-UP	AT LEAST EVERY 6 MONTHS
Fans	Check the connections and the direction of rotation	Check cleanliness. Clean, if necessary. Make sure that the impellers are not unbalanced. Make sure that the impellers do not cause noise when rotated by hand. Make sure that the fastening screws are not loose and free of mechanical damage. Check electrical connections and make sure that these are secured properly and are free of signs of corrosion.

6.3. COVER OPENING



Before opening the covers, first, unplug the unit from the mains, then wait for 2 minutes (until the fans completely stop).

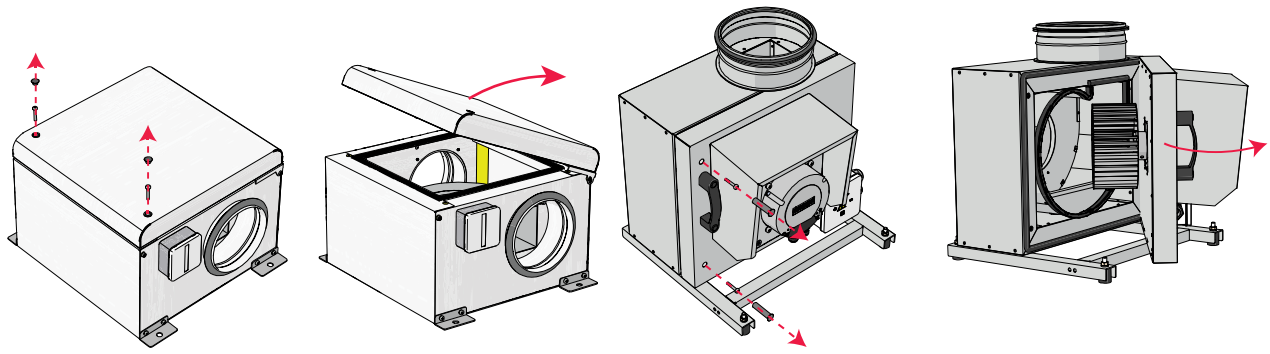

Fig. 6.3.1 AKU / AKU EKO

Fig. 6.3.2 KF T120 / KF T120 EC

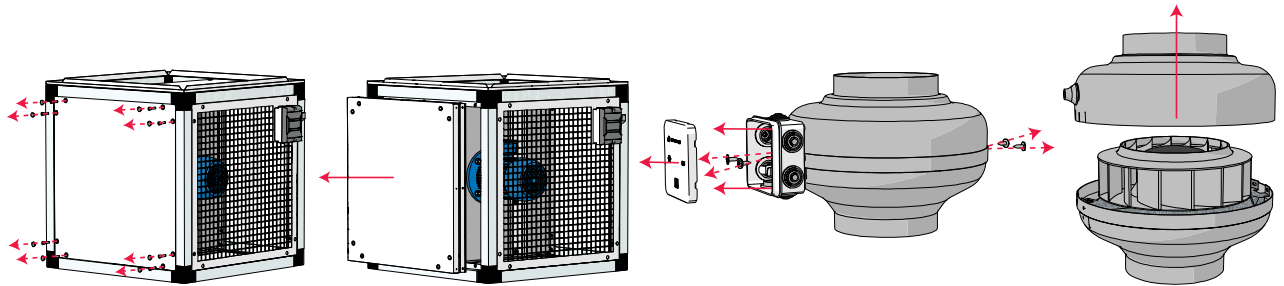

Fig. 6.3.3 KUB T120 / KUB EKO

Fig. 6.3.4 VKAP 3.0 / VKA EKO

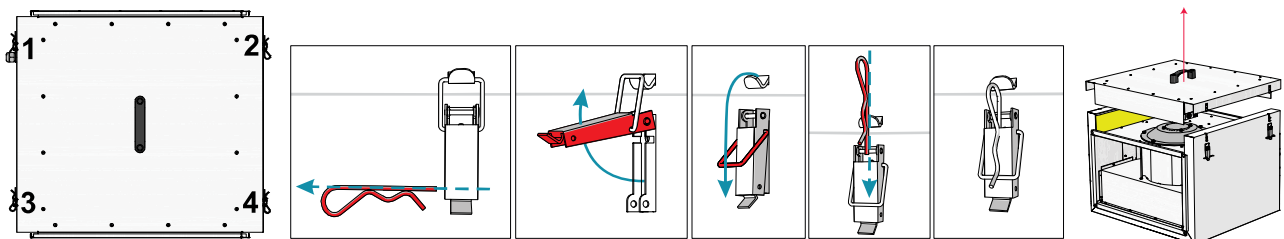

Fig. 6.3.5 VKSA

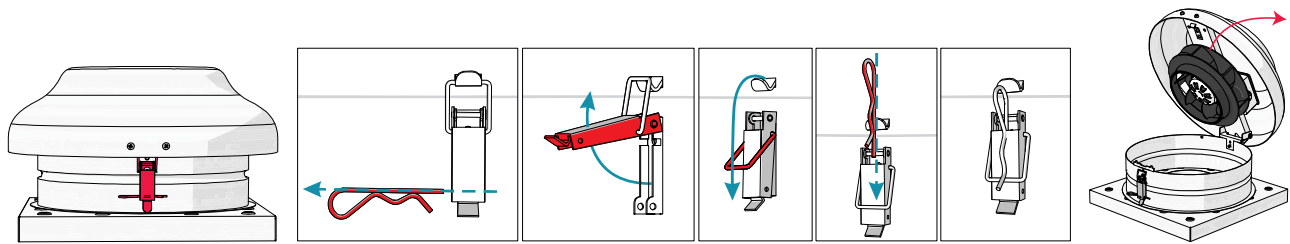

Fig. 6.3.6 VSA 3.0 / VSA EKO

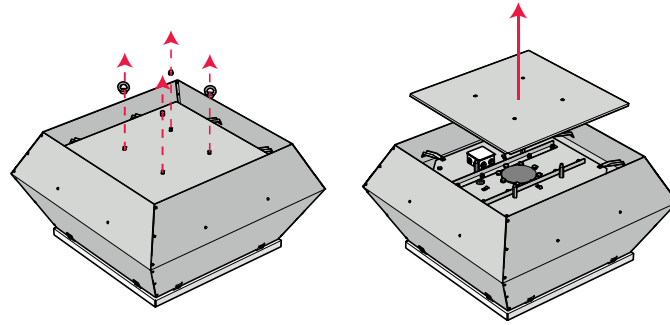

Fig. 6.3.7 VSV / VSV EKO / VSV EKO AL / VSVI / VSVI EKO / VSVI EKO AL

6.4. FAN MAINTENANCE

- Fan maintenance should be performed by experienced and trained staff only.
- The fan should be inspected and cleaned at least once per year.
- Prior to commencing any maintenance or repairs, make sure the fan is disconnected from the power source.
- Proceed to maintenance and repair after any fan rotation is stopped.
- Observe staff safety regulations during the maintenance and repair works.
- The fans features a heavy-duty ball bearing design. The motor is completely sealed and free of maintenance.
- Detach the fan from the unit.
- The impeller should be particularly checked for built-up material or debris that may cause an imbalance. An excessive imbalance may lead to accelerated wear on the motor bearings and cause vibration.
- Clean the impeller and inside the housing with a mild detergent and a damp soft cloth.
- Do not use high-pressure cleaners, abrasive materials and sharp tools or caustic solvents that may scratch or damage the housing and impeller.
- Do not plunge the motor in any fluid while cleaning the impeller. Make sure the impeller's balance weights are in place.
- Make sure the impeller is free of any obstacles.
- Install the fan back into the unit. Connect fan power and control signals.
- In case the fan does not automatically start up or stop after maintenance, contact the manufacturer. The malfunction of the fan can be identified by the pressure in the system (when pressure switches are connected) or by the protection signals of the fan unit.



Prior to commencing any maintenance or repair works, make sure the unit is disconnected from the power source.

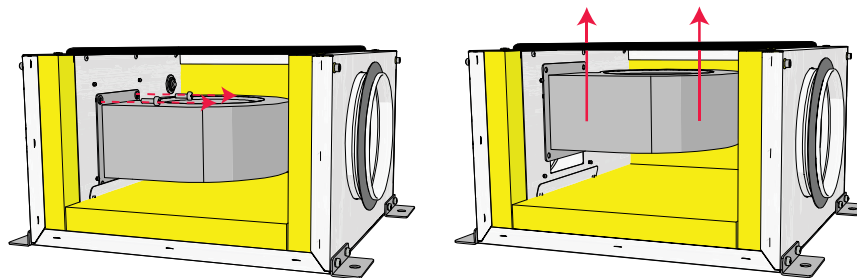

Fig. 6.4.1 AKU / AKU EKO

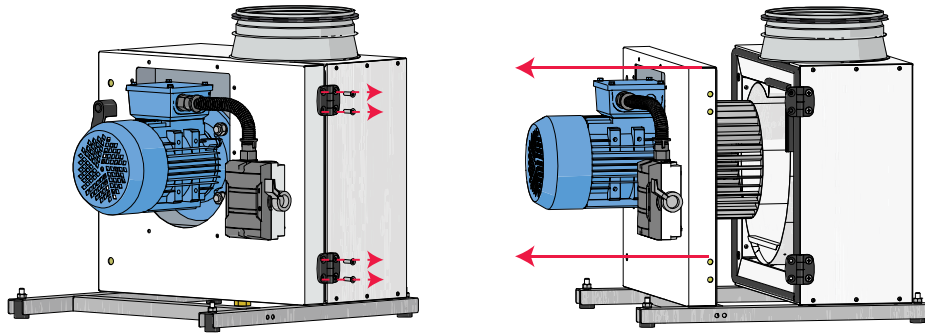

Fig. 6.4.2 KF T120 / KF T120 EC

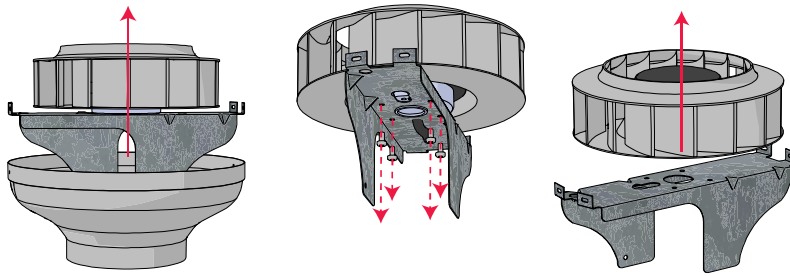

Fig. 6.4.3 VKAP 3.0 / VKA EKO

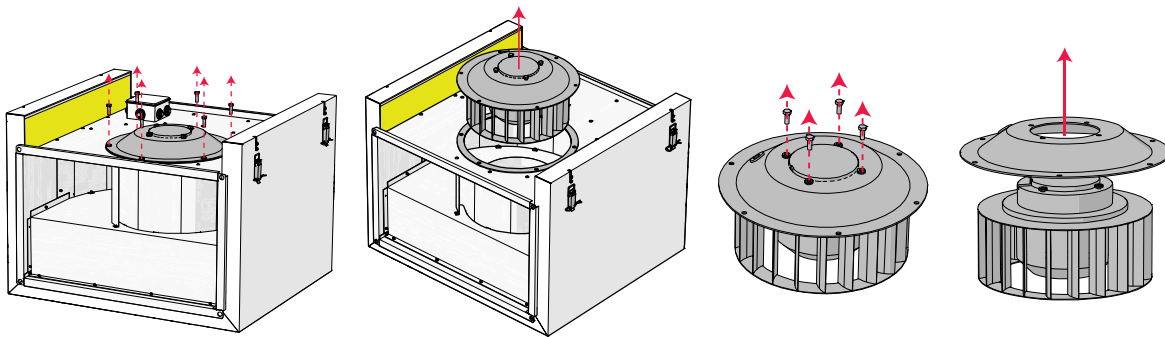

Fig. 6.4.4 VKS / VKSA

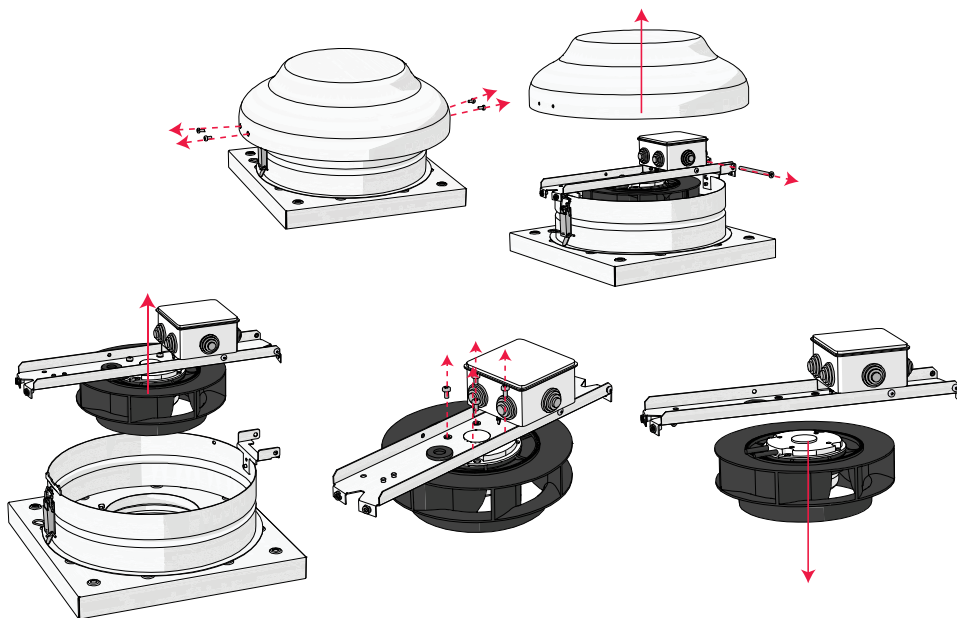

Fig. 6.4.5 VSA 3.0 / VSA EKO

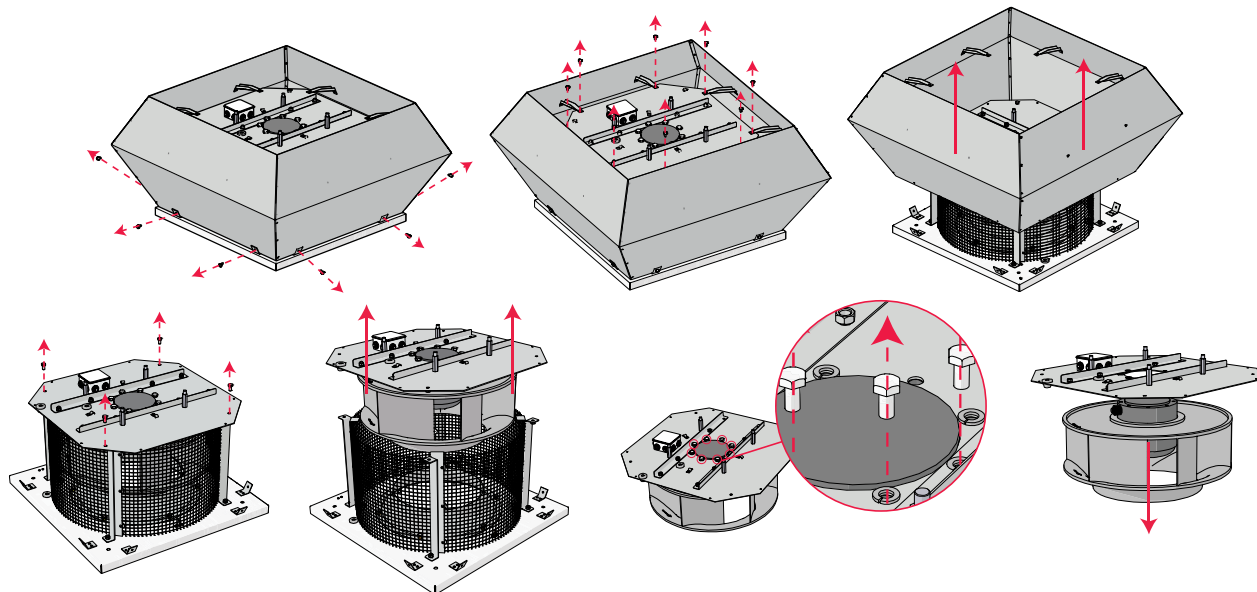

Fig. 6.4.6 VSV / VSV EKO / VSV EKO AL

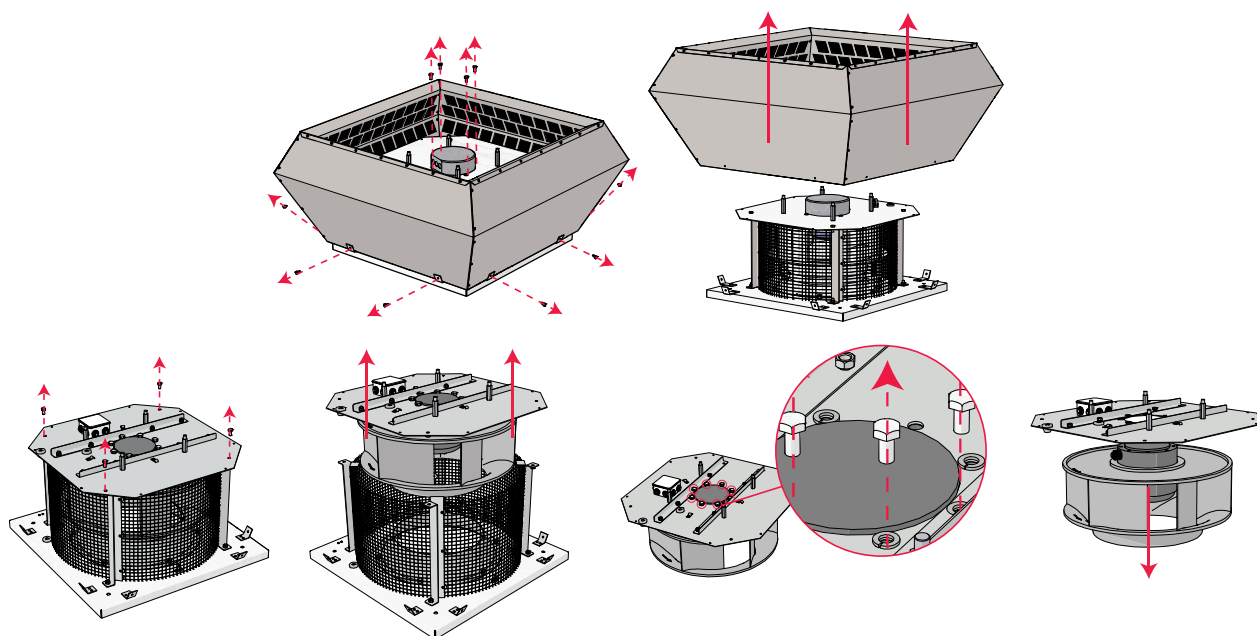

Fig. 6.4.7 VSVI / VSVI EKO / VSVI EKO AL

7. FAN SPEED CONTROL

Fan with EC motors speed is controlled with 0-10VDC signal input. Additional accessories (speed controllers) are used for users to control the desired fan speed from 0 to 100%.

VKA EKO units are integrated with fan speed control potentiometer inside of the connection box to set the desired speed.

VSVI EKO AL CPG units are integrated with UNIcon CPG-...AV sensor-control modules. These modules control fan speed by desired air pressure or flow. By default, air pressure tubes are connected for fan speed control by air flow. To prepare the unit to control fan speed by air pressure, tubes must be connected as shown in the VSVI EKO AL CPG diagram on section **"PIPING AND INSTRUMENTATION DIAGRAM"**. More information about fan control, control module configuration and preparation can be found in **"UNICON CPG-...AV OPERATING INSTRUCTIONS" (L-BAL-E253)**.

Fan with AC motors speed is controlled with supply voltage or frequency (depending on the fan unit model).

8. CONNECTION OF ACCESSORIES

8.1. CONNECTION OF EC FAN SPEED CONTROLLERS

AKU EKO, KF T120 EC, KUB EKO, VKA EKO, VSA EKO, VSV EKO AL, VSVI EKO AL.
 These fans can be connected with 0-10VDC fan speed controllers: MTP or SMT.

- MTP – allows to select fan speed from 0 to 100%. Controller position at 0 turns the device off.

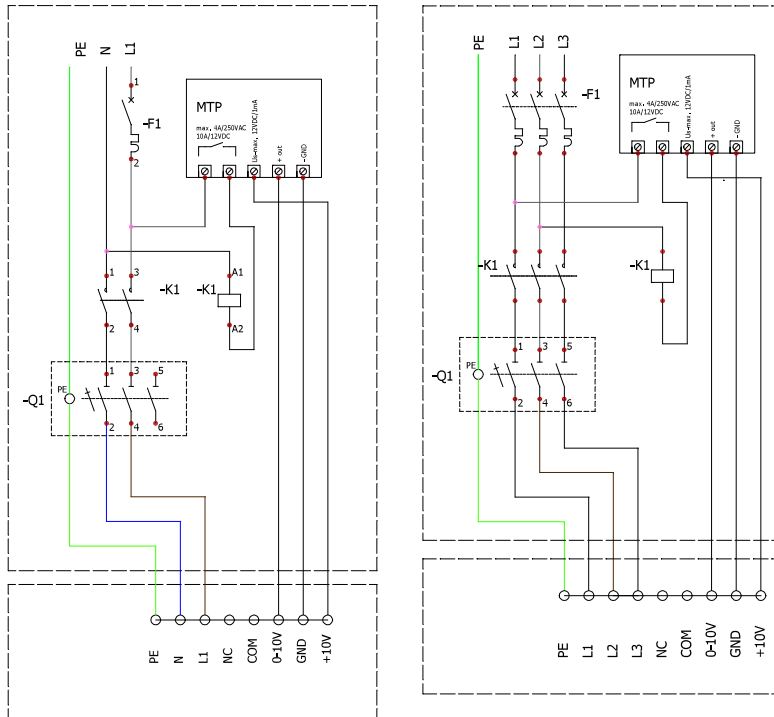

Fig. 8.1.1 MTP pinout and connection example

- SMT – allows to select 3 speeds. These speeds can be adjusted according to the user needs.

- 0 – position “Stop”;
- 1 – position 3-6VDC / 100mA;
- 2 – position 6-8VDC / 100mA;
- 3 – position 10V (supply voltage) / 100mA

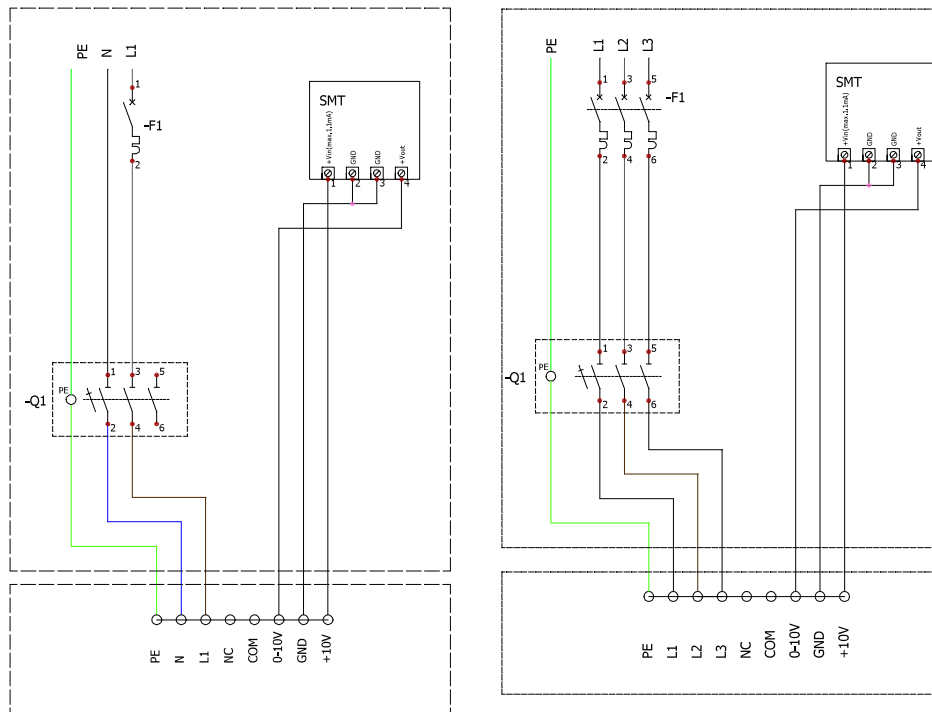

Fig. 8.1.2 SMT pinout and connection example

8.2. CONNECTION OF AC FAN SPEED CONTROLLERS

AKU, KF T120, KUB T120, VKAP 3.0, VKS, VKSA, VSA, VSV, VSVI, VSVI AL.

These fans can be controlled with different speed controllers, depending on unit's model and mains type. Typical (with 1x230VAC or 3x400VAC voltage) availability of controllers:

SPEED CONTROLLER	FAN UNITS
ETY / MTY *	AKU, VKAP 3.0, VKS L1, VKSA L1, VSA 3.0, VSV L1, VSVI L1, VSVI L1 AL
TGRV	
TGRT	VKS L3, VKSA L3, VSV L3, VSVI L3, VSVI L3 AL
ACS380	KF T120, KUB T120

* Max. current 4A. For units above 4A only TGRV controller available.

- ETY / MTY, TGRV, TGRT – allows to select fan speed by changing output voltage with rotating knob.

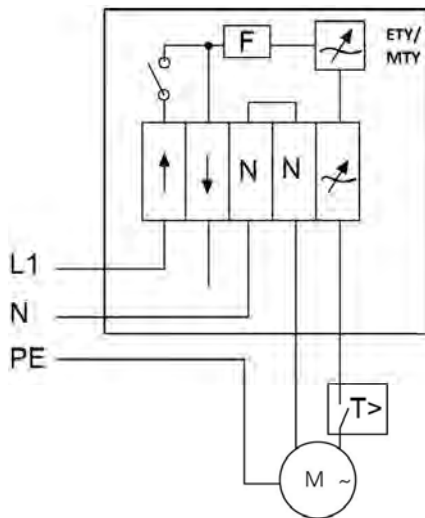

Fig. 8.2.1 ETY / MTY pinout and connection example

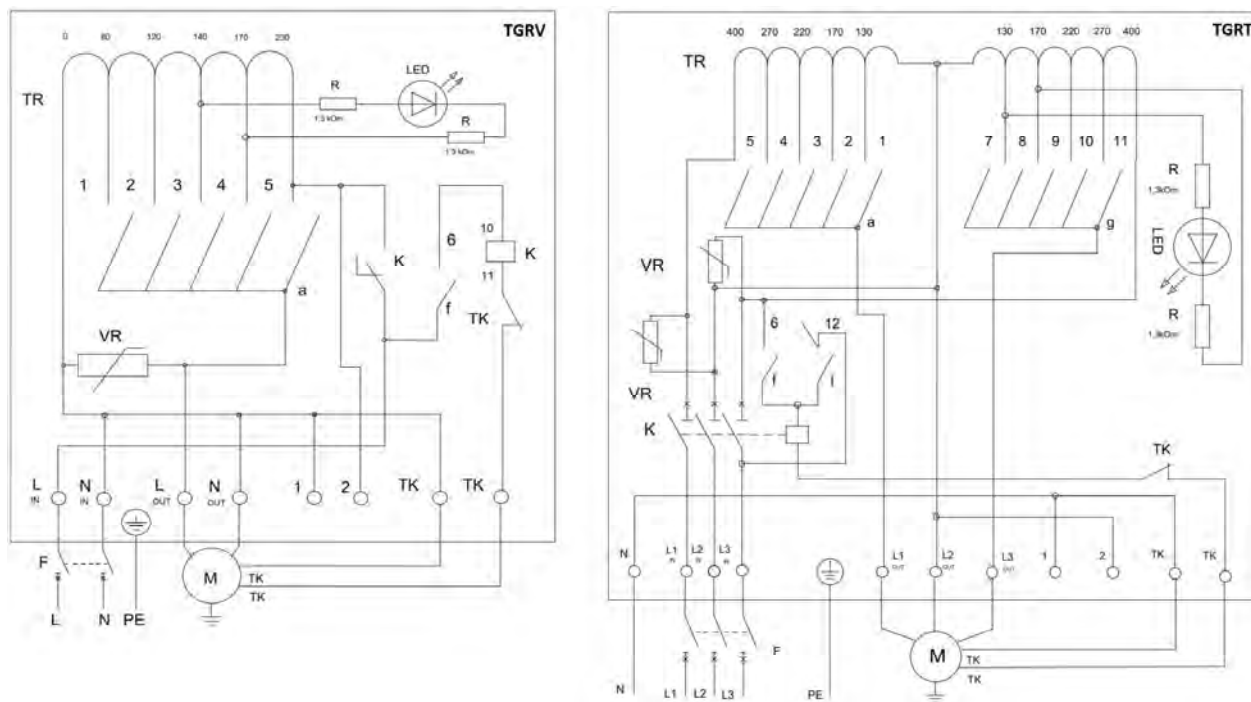

Fig. 8.2.2 TRGV / TRGT pinout and connection example

- ACS380 – allows to select fan speed by changing output voltage frequency with 0-10VDC signal.

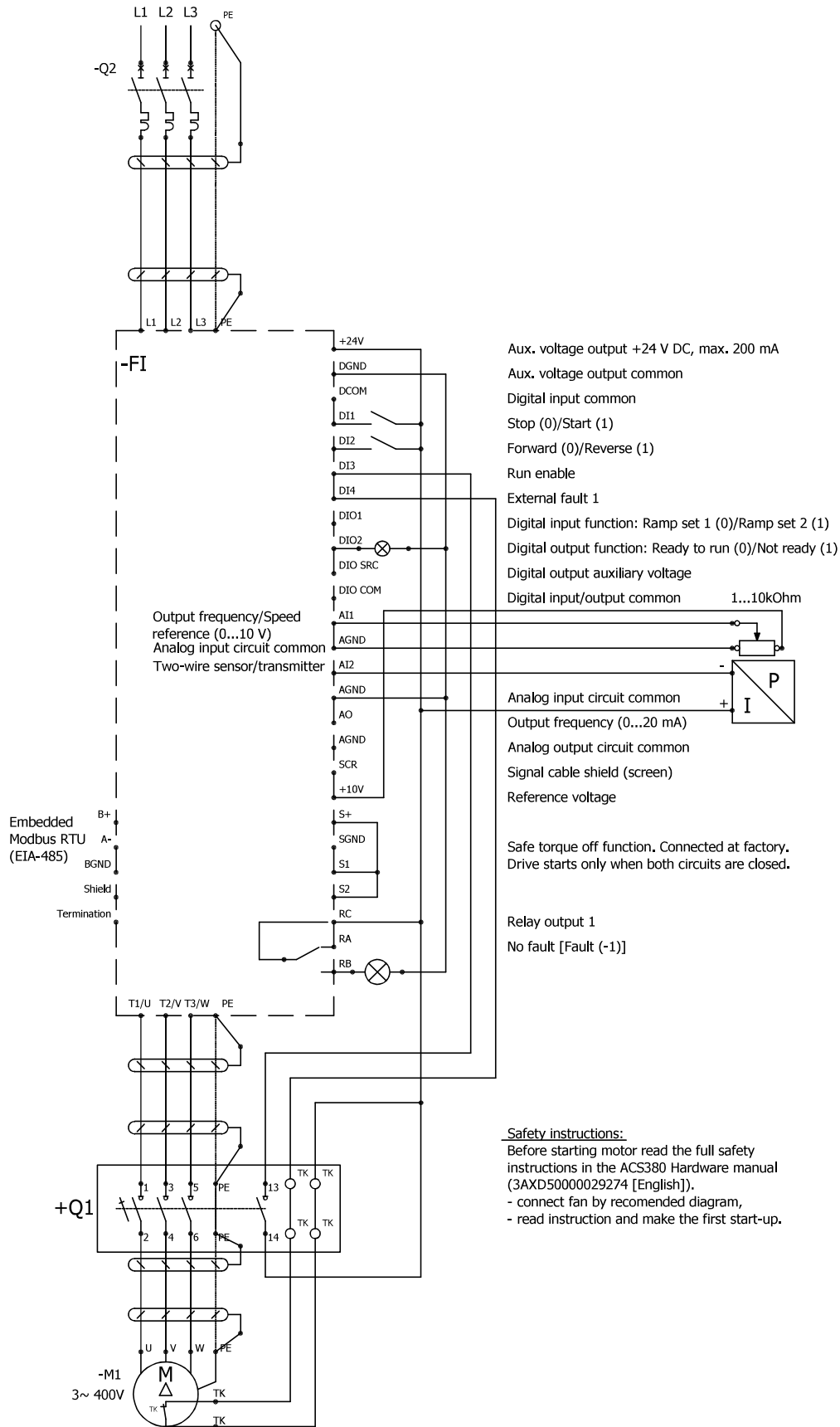

Fig. 8.2.3 ACS380 pinout and connection example

8.3. CONNECTION OF ON/OFF SAFETY SWITCH

Fan units can be connected to an external safety switch to ensure easy and safe unit disconnection from electric power source.

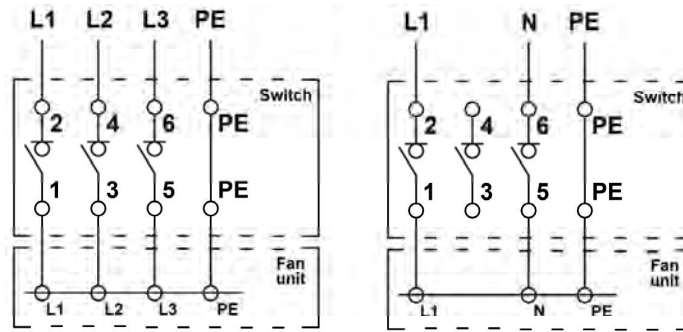

Fig. 8.3.1 Safety switch connection example

9. ELECTRICAL WIRING DIAGRAMS

On this section wiring diagrams of all fan units are present. To find your fan unit's corresponding diagram, on section **"TECHNICAL DATA"** find your fan unit and observe the number of its wiring diagram.



For the latest version of diagrams, check under the units terminal block cover.

GENERAL COLOUR CODING

BK	Black	YE	Yellow
GY	Grey	WH	White
PE	Yellow-green	RD	Red
BU	Blue	OG	Orange
BN	Brown	GN	Green

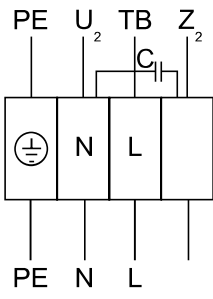
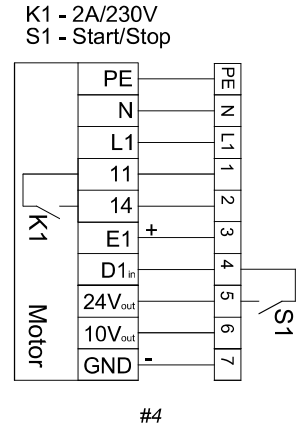
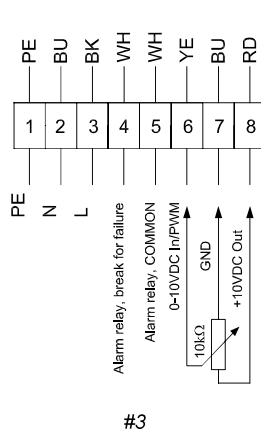
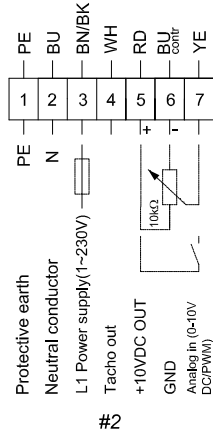
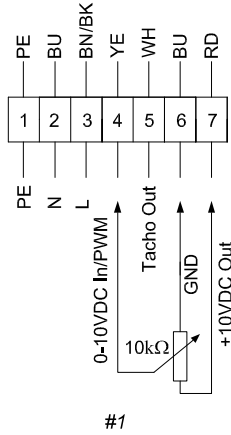

$Z_2 - BK; U_2 - BU; TB - BN$

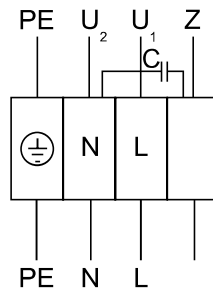

$U_2 - BK; U_1 - BU; Z - BN.$

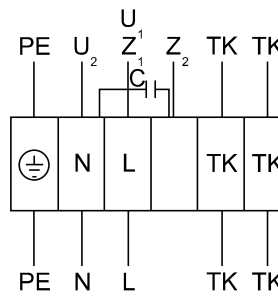

$Z_1 - BK; U_2 - BU; U_1 - BN; Z_2 - OG; TK - WH.$

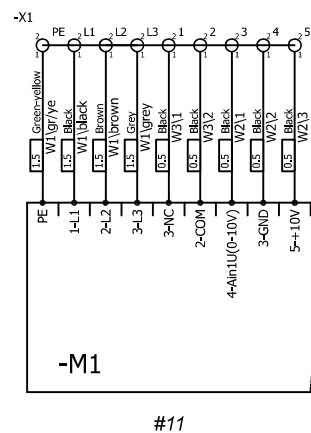
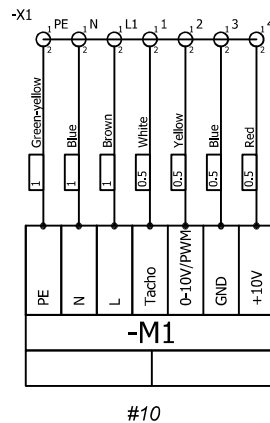
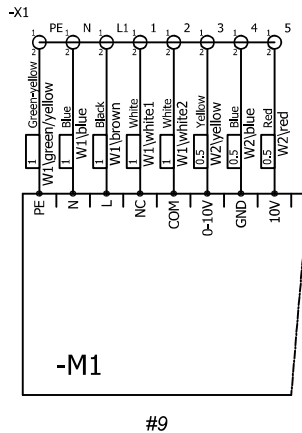
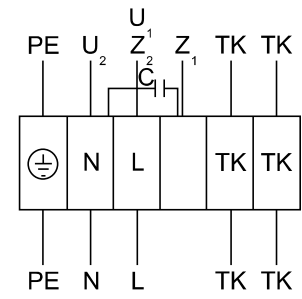

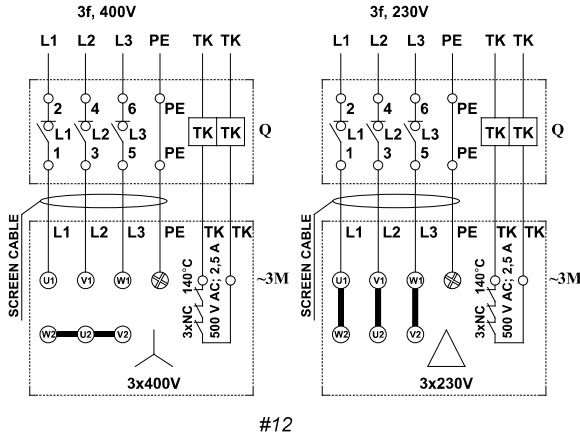

#12

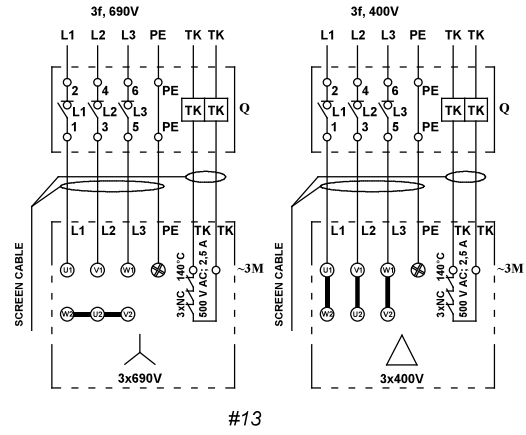

#13

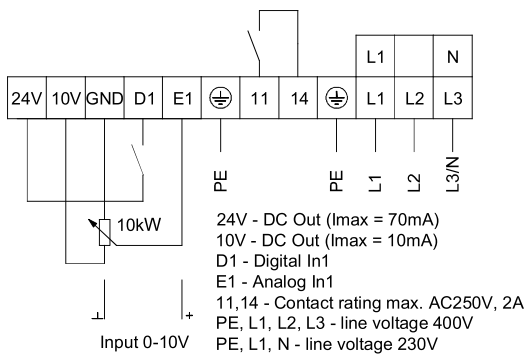

#14

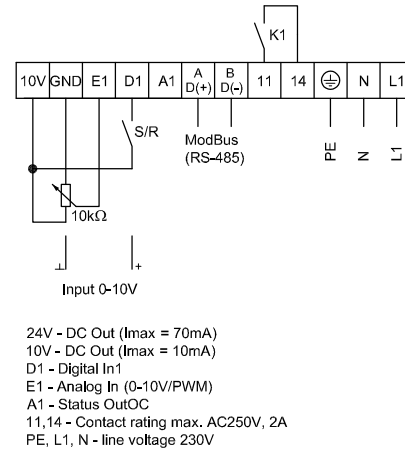

#15

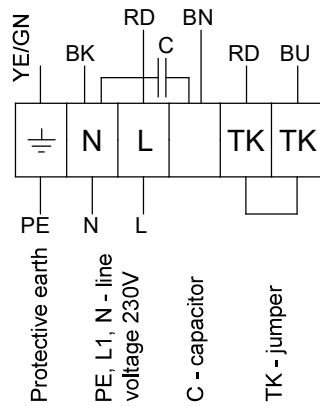

#16

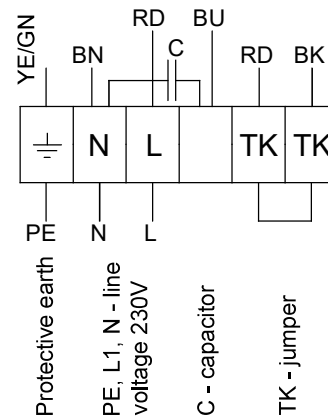

#17

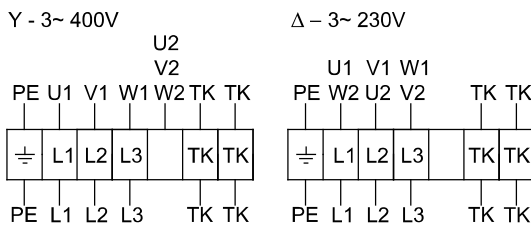

#18

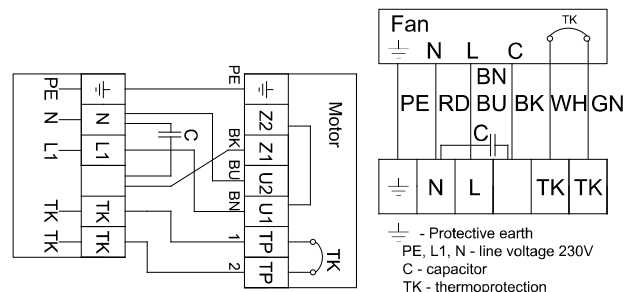

#19

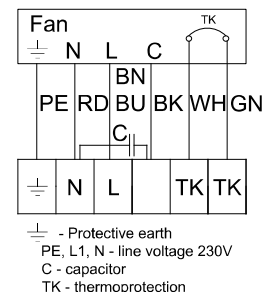

#20

U1 – BN; U2 – RD; V1 – BU; V2 – GY; W1 – BK; W2 – OG; TK – WH.

Y - 3~ 400V

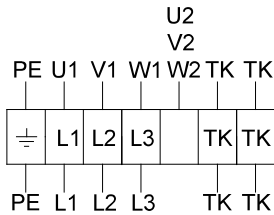

Δ - 3~ 230V

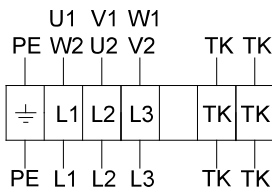

Connection Y
3~ 400V

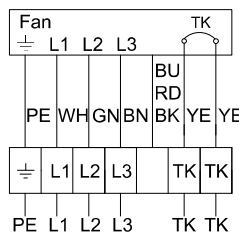

Connection Δ
3~ 400V

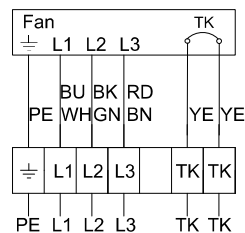

#21

#22

U1 – BN; U2 – BK; V1 – WH; V2 –RD; W1 – GN; W2 – BU; TK – YE.

Fan

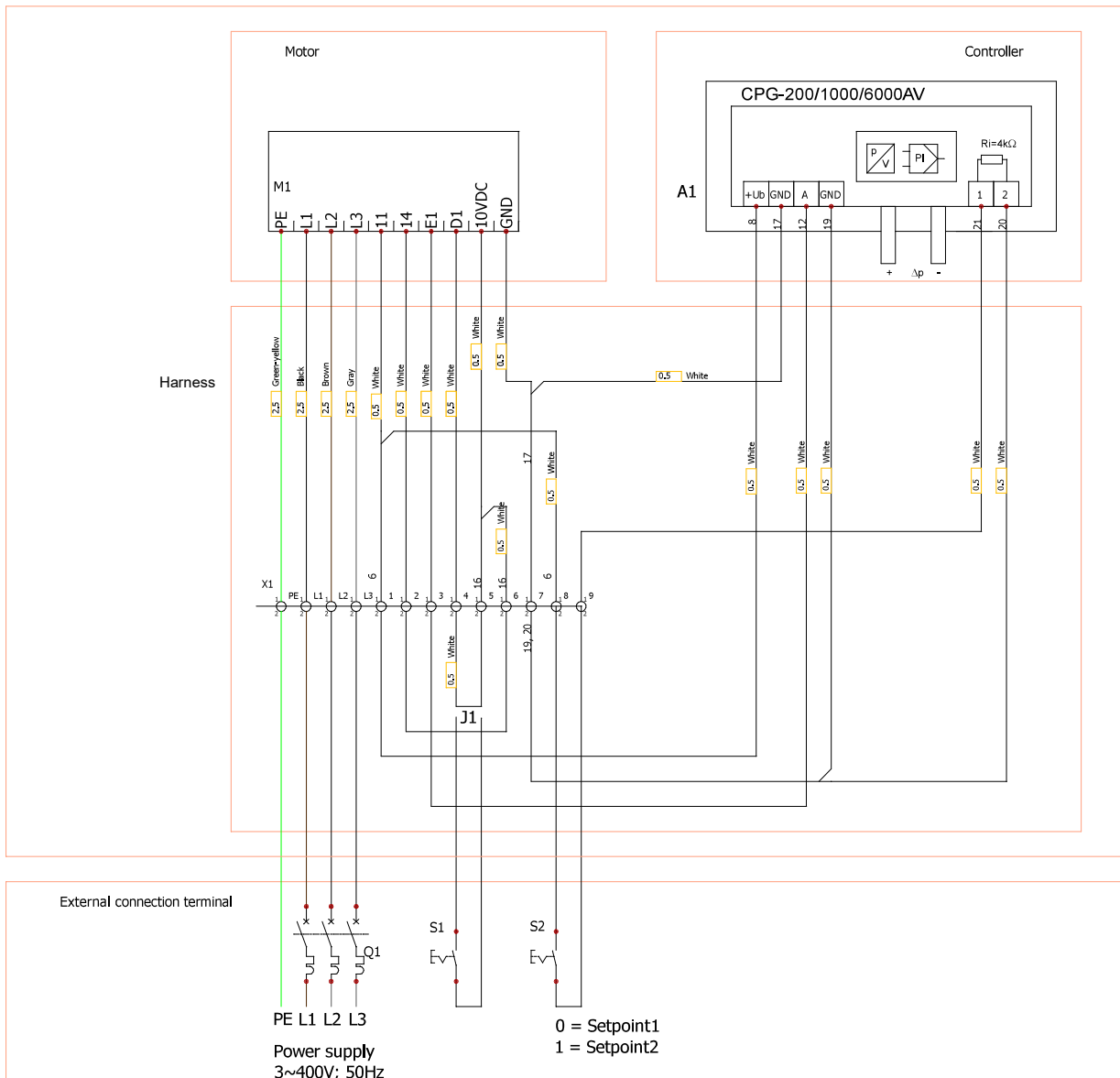

#23

Fan

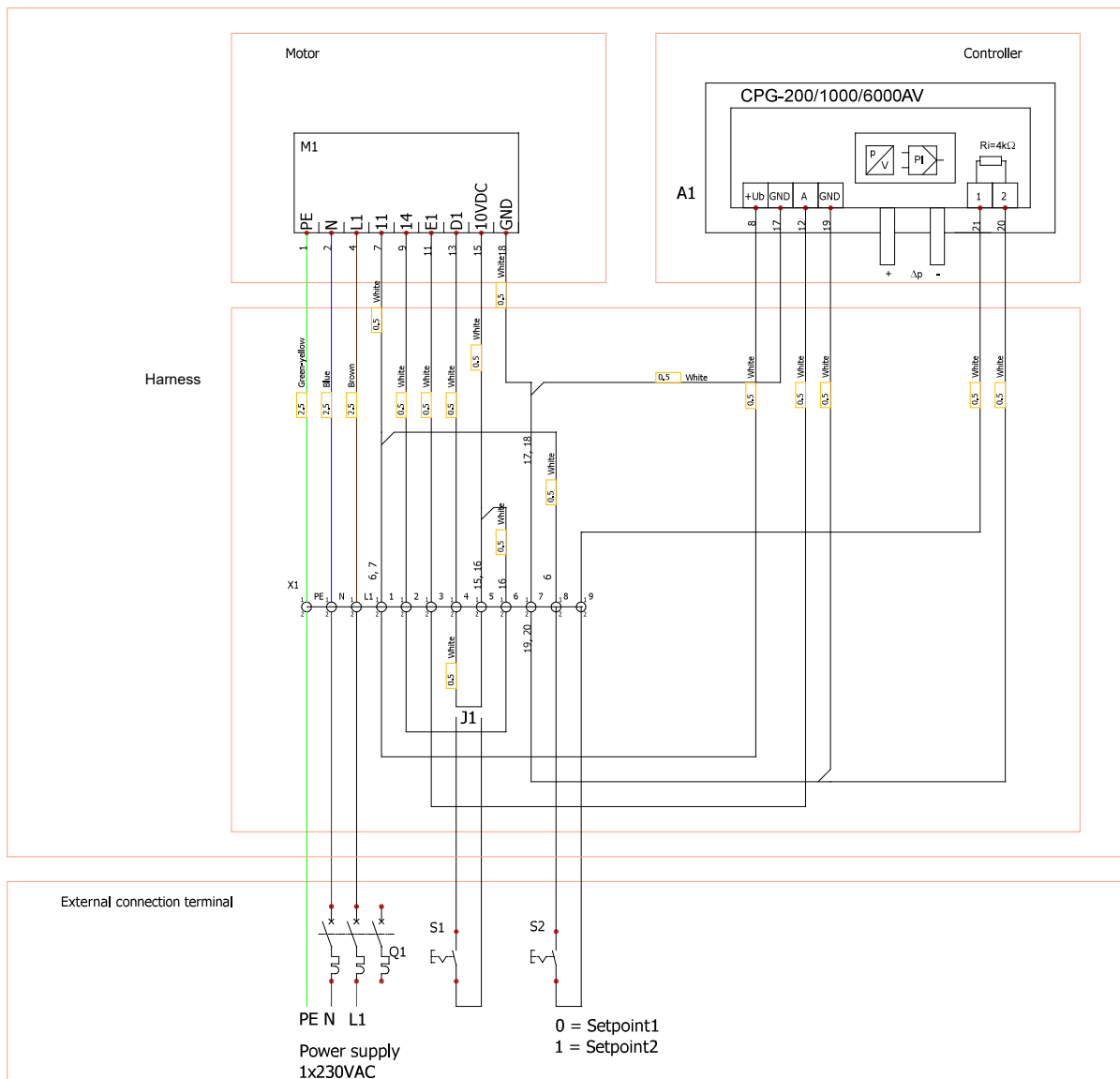

#24

GENERAL COLOUR CODING

BK	Black	YE	Yellow
GY	Grey	WH	White
PE	Yellow-green	RD	Red
BU	Blue	OG	Orange
BN	Brown	GN	Green

10. POSSIBLE FAULTS AND TROUBLESHOOTING

FAILURE	CAUSE	EXPLANATION/CORRECTIVE ACTIONS
The unit is not operating	No supply voltage	Check whether the device is connected to the power network.
	The protection device is off or a current leakage relay is active (if installed by the installer)	Switch on only if the unit condition has been evaluated by a qualified electrician. If the system failed, the failure MUST BE rectified prior to switching the system on.

11. ECODESIGN DATA TABLE

AKU		125 D	125 M	160 D	160 M	200 M	
Climate zone							
Average	Specific energy consumption (SEC)	[kWh/m ² a]	-24,7	-24,5	-23,2	-24,5	-25,1
	SEC Class		C	C	C	C	C
	AEC	[kWh/a]	146	151	203	152	130
	AHS	[kWh/a]	2830	2830	2830	2830	2830
Cold	Specific energy consumption (SEC)	[kWh/m ² a]	-51,7	-51,6	-50,3	-51,6	-52,1
	SEC Class		A+	A+	A+	A+	A+
	AEC	[kWh/a]	146	151	203	152	130
	AHS	[kWh/a]	5536	5536	5536	5536	5536
Warm	Specific energy consumption (SEC)	[kWh/m ² a]	-9,15	-9,01	-7,71	-8,99	-9,55
	SEC Class		F	F	F	F	F
	AEC	[kWh/a]	146	151	203	152	130
	AHS	[kWh/a]	1280	1280	1280	1280	1280
Topology		RVU/UVU	RVU/UVU	RVU/UVU	RVU/UVU	RVU/UVU	
Type of drive (fan)		Multi-speed	Multi-speed	Multi-speed	Multi-speed	Multi-speed	
Maximum airflow	[m ³ /h]	361	197	531	409	598	
Fan power at max airflow	[W]	114	72,6	201	127	152	
Casing sound power level (Lwa)	[dB(A)]	44	46	52	47	55	
Reference airflow	[m ³ /s]	0,07	0,038	0,103	0,079	0,116	
Reference pressure	[Pa]	50	50	50	50	50	
SPI	[W/(m ³ /h)]	0,22	0,23	0,31	0,23	0,2	
Control factor		0,65	0,65	0,65	0,65	0,65	
Declared maximum external leakage rates	[%]	1	1	1	1	1	
ErP Compliance		2018	2018	2018	2018	2018	
Internet address for disassembly instructions		www.salda.it					

AKU EKO		125	160	200	250	315	700X400	700X400 S
Topology		NRVU/UVU	NRVU/UVU	NRVU/UVU	NRVU/UVU	NRVU/UVU	NRVU/UVU	NRVU/UVU
Type of drive (fan)		Variable	Variable	Variable	Variable	Variable	Variable	Variable
Nominal NRVU flow rate	[m ³ /s]	0,068	0,106	0,17	0,215	0,325	0,736	1,019
Effective electric power input	[W]	55,1	70,3	169	219	395	938	1323
Face velocity	[m/s]	0,971	1,15	1,17	N/A	N/A	N/A	N/A
Nominal external pressure	[Pa]	236	250	449	380	541	597	657
Static efficiency of fans used in accordance with Regulation (EU) No 327/2011	[%]	29,2	37,8	45,2	37,4	44,6	46,8	50,6
Declared maximum external leakage rates (CAL(R) @ +400 Pa)	[%]	1	1	1	<1	<1	<1	<1
Declared maximum external leakage rates (CAL(R) @ -400 Pa)	[%]	1	1	1	<1	<1	<1	<1
Casing sound power level (Lwa)	[dB(A)]	57	44	64	63	67	62	67
ErP Compliance		2018	2018	2018	2018	2018	2018	2018
Internet address for disassembly instructions		www.salda.it						

VKAP 3.0		100 LD	100 MD	125 LD	125 MD	150 LD	160 LD	160 MD	
Climate zone									
Average	Specific energy consumption (SEC)	[kWh/m ² a]	-24,9	-24,3	-25	-23,7	-25,2	-25,7	-25,5
	SEC Class		C	C	C	C	C	C	C
	AEC	[kWh/a]	134	161	132	185	124	103	111
	AHS	[kWh/a]	2830	2830	2830	2830	2830	2830	2830
Cold	Specific energy consumption (SEC)	[kWh/m ² a]	-52	-51,3	-52,1	-50,7	-52,3	-52,8	-52,6
	SEC Class		A+	A+	A+	A+	A+	A+	A+
	AEC	[kWh/a]	134	161	132	185	124	103	111
	AHS	[kWh/a]	5536	5536	5536	5536	5536	5536	5536
Warm	Specific energy consumption (SEC)	[kWh/m ² a]	-9,44	-8,76	-9,5	-8,18	-9,71	-10,5	-10
	SEC Class		F	F	F	F	F	E	E
	AEC	[kWh/a]	134	161	132	185	124	103	111
	AHS	[kWh/a]	1280	1280	1280	1280	1280	1280	1280
Topology		NRVU/ BVU	NRVU/ BVU	NRVU/ BVU	NRVU/ BVU	NRVU/ BVU	NRVU/ BVU	NRVU/ BVU	
Type of drive (fan)		Multi-speed	Multi-speed	Multi-speed	Multi-speed	Multi-speed	Multi-speed	Multi-speed	
Maximum airflow	[m ³ /h]	291	190	296	150	531	668	358	
Fan power at max airflow	[W]	68,2	47,4	69,1	41	99,1	94,1	68,8	
Casing sound power level (Lwa)	[dB(A)]	54	49	48	38	53	49	50	
Reference airflow	[m ³ /s]	0,057	0,037	0,058	0,029	0,103	0,13	0,07	
Reference pressure	[Pa]	50	50	50	30,3	39,7	50	50	
SPI	[W/(m ³ /h)]	0,2	0,25	0,2	0,28	0,19	0,16	0,17	
Control factor		0,65	0,65	0,65	0,65	0,65	0,65	0,65	
Declared maximum external leakage rates	[%]	1	1	1	1	1	1	1	
ErP Compliance		2018	2018	2018	2018	2018	2018	2018	
Internet address for disassembly instructions		www.salda.lt							

VKA EKO		125	150	160	200	250	315
Topology		NRVU/ UVU	NRVU/ UVU	NRVU/ UVU	NRVU/ UVU	NRVU/ UVU	NRVU/ UVU
Type of drive (fan)		Variable	Variable	Variable	Variable	Variable	Variable
Nominal NRVU flow rate	[m ³ /s]	0,055	0,075	0,075	0,143	0,164	0,186
Effective electric power input	[W]	70	69,4	78,2	166	163	162
Face velocity	[m/s]	1,2	1,6	1,6	1,54	1,77	1,47
Nominal external pressure	[Pa]	294	291	291	441	400	392
Static efficiency of fans used in accordance with Regulation (EU) No 327/2011	[%]	24,4	31,4	27,9	38,1	40,3	44,9
Declared maximum external leakage rates (CAL(R) @ +400 Pa)	[%]	3	3	3	3	3	3
Declared maximum external leakage rates (CAL(R) @ -400 Pa)	[%]	3	3	3	3	3	3
Casing sound power level (Lwa)	[dB(A)]	60	58	64	54	53	60
ErP Compliance		2018	2018	2018	2018	2018	2018
Internet address for disassembly instructions		www.salda.lt					

KUB EKO		50-355	67-400	67-500	80-560	80-630	100-630
Topology		NRVU/VU	NRVU/VU	NRVU/VU	NRVU/VU	NRVU/VU	NRVU/VU
Type of drive (fan)		Variable	Variable	Variable	Variable	Variable	Variable
Nominal NRVU flow rate	[m ³ /s]	0,466	0,833	1,414	1,661	2,574	2,887
Effective electric power input	[W]	406	788	1273	1521	2984	2895
Face velocity	[m/s]	N/A	N/A	N/A	N/A	N/A	N/A
Nominal external pressure	[Pa]	422	493	448	494	600	580
Static efficiency of fans used in accordance with Regulation (EU) No 327/2011	[%]	48,4	52,1	49,7	54	51,8	57,8
Declared maximum external leakage and maximum internal leakage	[%]	<1	<1	<1	<1	<1	<1
Casing sound power level (Lwa)	[dB(A)]	57	59	62	67	73	76
ErP Compliance		2018	2018	2018	2018	2018	2018
Internet address for disassembly instructions		www.salda.it					

VKS / VKSA		600-300-4 L3	600-350-4 L3	700-400-4 L3	800-500-6 L3
Topology		NRVU/VU	NRVU/VU	NRVU/VU	NRVU/VU
Type of drive (fan)		Multi-speed	Multi-speed	Multi-speed	Multi-speed
Nominal NRVU flow rate	[m ³ /s]	0,413	0,489	0,592	0,903
Effective electric power input	[W]	530	756	1048	1011
Face velocity	[m/s]	N/A	N/A	N/A	N/A
Nominal external pressure	[Pa]	490	624	781	490
Static efficiency of fans used in accordance with Regulation (EU) No 327/2011	[%]	38,1	40,4	44,1	43,8
Declared maximum external leakage and maximum internal leakage	[%]	<1	<1	<1	<1
Casing sound power level (Lwa)	[dB(A)]	54	54	59	69
ErP Compliance		2018	2018	2018	2018
Internet address for disassembly instructions		www.salda.it			

VSA 3.0		190 L	190 S	220 M	220 S	225 L	250 L	
Climate zone								
Average	Specific energy consumption (SEC)	[kWh/m ² a]	-25,7	-24,7	-26,1	-25,2	-26,4	-24,8
	SEC Class		C	C	B	C	B	C
	AEC	[kWh/a]	105	144	88,1	122	77,2	141
	AHS	[kWh/a]	2830	2830	2830	2830	2830	2830
Cold	Specific energy consumption (SEC)	[kWh/m ² a]	-52,7	-51,8	-53,2	-52,3	-53,4	-51,8
	SEC Class		A+	A+	A+	A+	A+	A+
	AEC	[kWh/a]	105	144	88,1	122	77,2	141
	AHS	[kWh/a]	5536	5536	5536	5536	5536	5536
Warm	Specific energy consumption (SEC)	[kWh/m ² a]	-10,2	-9,19	-10,6	-9,74	-10,9	-9,27
	SEC Class		E	F	E	F	E	F
	AEC	[kWh/a]	105	144	88,1	122	77,2	141
	AHS	[kWh/a]	1280	1280	1280	1280	1280	1280
Topology		NRVU/BVU	NRVU/BVU	NRVU/BVU	NRVU/BVU	NRVU/BVU	NRVU/BVU	
Type of drive (fan)		Multi-speed	Multi-speed	Multi-speed	Multi-speed	Multi-speed	Multi-speed	
Maximum airflow	[m ³ /h]	354	184	666	302	880	1076	
Fan power at max airflow	[W]	74,2	46,7	97,2	67	123	206	
Casing sound power level (Lwa)	[dB(A)]	54	56	54	56	54	56	
Reference airflow	[m ³ /s]	0,069	0,036	0,13	0,059	0,171	0,209	
Reference pressure	[Pa]	50	35,7	49,2	40,2	55,1	51,7	
SPI	[W/(m ³ /h)]	0,16	0,22	0,13	0,19	0,12	0,21	
Control factor		0,65	0,65	0,65	0,65	0,65	0,65	
Declared maximum external leakage rates	[%]	1	1	1	1	1	1	
ErP Compliance		2018	2018	2018	2018	2018	2018	
Internet address for disassembly instructions		www.salda.it						

VSA EKO		190	220	225	250
Topology		NRVU/VU	NRVU/VU	NRVU/VU	NRVU/VU
Type of drive (fan)		Multi-speed	Multi-speed	Multi-speed	Multi-speed
Nominal NRVU flow rate	[m ³ /s]	0,082	0,119	0,148	0,277
Effective electric power input	[W]	80	95	162	360
Face velocity	[m/s]	N/A	N/A	N/A	N/A
Nominal external pressure	[Pa]	361	278	472	481
Static efficiency of fans used in accordance with Regulation (EU) No 327/2011	[%]	36,9	34,8	43,1	37
Declared maximum external leakage and maximum internal leakage	[%]	<1	<1	<1	<1
Casing sound power level (Lwa)	[dB(A)]	72	73	79	82
ErP Compliance		2018	2018	2018	2018
Internet address for disassembly instructions		www.salda.it			

VSV / VSVI / VSVI AL		311-4 L1	355-4 L1	355-4 L3	400-4 L1	400-4 L3
Topology		NRVU/UVU	NRVU/UVU	NRVU/UVU	NRVU/UVU	NRVU/UVU
Type of drive (fan)		Multi-speed	Multi-speed	Multi-speed	Multi-speed	Multi-speed
Nominal NRVU flow rate	[m ³ /s]	0,36	0,61	0,457	0,64	0,631
Effective electric power input	[W]	164	297	243	506	434
Face velocity	[m/s]	N/A	N/A	N/A	N/A	N/A
Nominal external pressure	[Pa]	160	185	207	314	255
Static efficiency of fans used in accordance with Regulation (EU) No 327/2011	[%]	35,2	38,2	39	39,8	37,1
Declared maximum external leakage and maximum internal leakage	[%]	<1	<1	<1	<1	<1
Casing sound power level (Lwa)	[dB(A)]	67	68	64	73	68
ErP Compliance		2018	2018	2018	2018	2018
Internet address for disassembly instructions		www.salda.it				

VSV / VSVI / VSVI AL		450-4 L1	450-4 L3	500-4 L3	560-4 L3	630-6 L3
Topology		NRVU/UVU	NRVU/UVU	NRVU/UVU	NRVU/UVU	NRVU/UVU
Type of drive (fan)		Multi-speed	Multi-speed	Multi-speed	Multi-speed	Multi-speed
Nominal NRVU flow rate	[m ³ /s]	1,35	1,22	1,31	1,76	1,759
Effective electric power input	[W]	858	896	1309	2150	1229
Face velocity	[m/s]	N/A	N/A	N/A	N/A	N/A
Nominal external pressure	[Pa]	286	352	440	579	308
Static efficiency of fans used in accordance with Regulation (EU) No 327/2011	[%]	44,9	47,8	44,1	47,4	44,1
Declared maximum external leakage and maximum internal leakage	[%]	<1	<1	<1	<1	<1
Casing sound power level (Lwa)	[dB(A)]	80	74	72	80	74
ErP Compliance		2018	2018	2018	2018	2018
Internet address for disassembly instructions		www.salda.it				

		VSV 250-2SL1	VSV EKO AL / VSVI EKO AL 311-L1	VSV EKO AL / VSVI EKO AL 450-L3	VSV EKO AL / VSVI EKO AL 500-L3	
Topology		NRVU/UVU	NRVU/UVU	NRVU/UVU	NRVU/UVU	
Type of drive (fan)		Multi-speed	Variable	Variable	Variable	
Nominal NRVU flow rate	[m ³ /s]	0,26	0,35	1,17	1,34	
Effective electric power input	[W]	224	319	1418	1280	
Face velocity	[m/s]	N/A	N/A	N/A	N/A	
Nominal external pressure	[Pa]	285	393	616	470	
Static efficiency of fans used in accordance with Regulation (EU) No 327/2011	[%]	32,8	43,1	50,9	49,4	
Declared maximum external leakage and maximum internal leakage	[%]	<1	<1	<1	<1	
Casing sound power level (Lwa)	[dB(A)]	71	75	80	78	
ErP Compliance		2018	2018	2018	2018	
Internet address for disassembly instructions		www.salda.it				

12. DECLARATION OF CONFORMITY

Manufacturer

SALDA, UAB
Ragainės g. 100
LT-78109 Šiauliai, Lithuania
Tel.: +370 41 540415
www.salda.lt

Hereby confirms that the following products - Air handling units:

FAN*

(where by “*” indicates possible unit installation type and modification)

Provided it was delivered and installed in the facility in accordance with the included installation instructions, comply with all applicable requirements in the following directives and regulations:

Machinery Directive 2006 / 42 / EC
Low Voltage Directive 2014 / 35 / EU
EMC Directive 2014 / 30 / EU
RoHS 2 Directive 2011 / 65 / EU
Energy labeling of residential units Nr. 1254 / 2014
Ecodesign requirements for ventilation units Nr. 1253 / 2014

The following harmonized standards are applied in applicable parts:

EN ISO 12100:2012 - Safety of machinery - General principles for design - Risk assessment and risk reduction.
EN 60335-1:2012 - Household and similar electrical appliances. Safety. Part 1: General requirements.
EN 60529:1999/A2:2014/AC:2019 - Degrees of protection provided by enclosures (IP code).
EN 60204-1:2018 - Safety of machinery - Electrical equipment of machines - Part 1: General requirements.
EN IEC 61000-6-1:2019-03 - Electromagnetic compatibility (EMC) -- Part 6-1: Generic standards - Immunity for residential, commercial and light-industrial environments.
LST EN 61000-6-2:2019 - Electromagnetic compatibility (EMC) -- Part 6-2: Generic standards - Immunity for industrial environments.
LST EN 61000-6-3:2008 - Electromagnetic compatibility (EMC) -- Part 6-3: Generic standards - Emission standard for residential, commercial and light-industrial environments.

Should any alterations be made in the products, this declaration will no longer apply.

Quality: SALDA UAB activities are in line with the international quality management system standard **ISO 9001:2015**.

Date 2022-02-02



Giedrius Taujenis
Director product development

13. WARRANTY

1. All equipment manufactured in our factory is checked in operating conditions and tested before delivery. The test protocol is supplied together with the unit. The equipment is shipped in good working condition to the end client. The unit is warranted for the period of two years from the date of the invoice.
2. If equipment is found to have been damaged during transportation, a claim should be made against the carrier, as we assume no responsibility for such damage.
3. This warranty does not apply:
 - 3.1. when transportation, storage, installation and maintenance instructions of the unit are violated;
 - 3.2. when the equipment is improperly maintained, mounted - inadequate maintenance;
 - 3.3. when the equipment without our knowledge and permission has been upgraded or unskilled repairs were made;
 - 3.4. when the unit was used not for its original purpose.
 - 3.5. Company SALDA UAB is not responsible for potential loss of property or personal injury in cases where the Air Handling unit is manufactured without the control system and the control system is installed by the client or the third parties. The manufacturer's warranty does not cover devices that will be damaged by installing the control system.
4. This warranty does not apply to these malfunction cases:
 - 4.1. mechanical damage;
 - 4.2. damage caused by entering outside objects, materials and liquids;
 - 4.3. damage caused by natural disasters, accidents (voltage change in the electricity network, lightning, etc.).
5. The company assumes no liability for the damage to its products neither directly nor indirectly, if the damage is caused by failure to comply with the installation and mounting regulations, deliberate or careless users or third-party behaviour.

These conditions are readily discernible when the equipment is returned to our factory for inspection. If the direct client determines that equipment is found to be faulty, or a breakdown occurred, he should inform the manufacturer within five working days and deliver the equipment to the manufacturer. Delivery costs should be covered by the customer.



The manufacturer reserves the right to change this technical passport at any time without prior notice if some typographic errors or inaccurate information is found, as well as after improving the apps and/or the devices. Such changes will be included in the new issues of the technical passport. All illustrations are just for information and thus may differ from the original device. The newest manual version is available at <https://select.salda.it>

13.1. LIMITED WARRANTY COUPON

Warranty term
24 months*

I received the complete package and technical manual of the product ready for usage. I have read the warranty terms and conditions and agree with them:

.....
 Customer's signature

*Refer to WARRANTY CONDITIONS

Dear User, we appreciate your choice and do hereby guarantee that all ventilation equipment manufactured by our Company is inspected and thoroughly tested. An operational and high-quality product is sold to the direct buyer and shipped from the territory of the factory. It is provided with a 24-month warranty from the issue date of the invoice. Your opinion is important to us, thus we always look forward to hearing your comments, feedback, or suggestions regarding technical and operational characteristics of the Products. In order to avoid any misunderstandings, please read the instructions for installation and operation of the product as well as other technical documents of the product carefully. The number of the Limited Warranty Coupon and the serial number of the product specified on the silver identification sticker attached to the housing must match. The Limited Warranty Coupon shall be valid provided that the seller's stamps and records are clear. It is not allowed to change, delete, or rewrite the data specified on it in any manner – such a coupon shall be invalid. With this Limited Warranty Coupon the manufacturer confirms his obligations to implement the imperative requirements established by effective laws on protection of consumer rights in the event of identification of any defects of the products. The manufacturer reserves the right to refuse provision of free warranty servicing in cases when the warranty conditions listed below are disregarded.

PRODUCT MAINTENANCE TABLE

Product name*

lot number*

Installation	Interval	Date
Fan cleaning	Once per year**	

* - Look at the product label.

** - At least.



NOTE. The customer shall be required to complete the Product Maintenance Table.

MANUALS IN OTHER LANGUAGES

DE



<https://select.salda.lt/file/fans-de>

DK



<https://select.salda.lt/file/fans-dk>

FR



<https://select.salda.lt/file/fans-fr>

IT



<https://select.salda.lt/file/fans-it>

LT



<https://select.salda.lt/file/fans-lt>

NL



<https://select.salda.lt/file/fans-nl>

PL



<https://select.salda.lt/file/fans-pl>



MAN000393



Ragainės g. 100
Šiauliai LT-78109, LITHUANIA

+370 41 540 415
office@salda.lt