

LPKB 250 D1 EC

- Low profile duct fan with circular connections.
- A small and useful duct fan which are perfect for spaces with minimum height clearance.
- With one connection on the inlet side.
- High capacity and efficiency with low sound levels.
- Impeller with backward curved blades.
- The external rotor motor has maintenance-free sealed ball-bearings and is very energy efficient.
- Speed controlling can be done with the built-in potentiometer, 0-10 V alt. external control.
- Integrated motor protection.
- Junction box has enclosure class IP 54.
- Fan housing is manufactured from galvanized sheet steel.
- Duct connections are equipped with rubber seals.
- The fan is intended to be installed in a duct system.
- A duct connected fan can be installed outside or in damp environments.
- The mounting brackets simplify installation in any position.

Accessories

- Speed controller MS EC
- Controller IQ-Reg EC
- Pressure regulator CALAIR-PR-230V
- Pressure regulator FKP-R
- MK 250
- FLK 250
- FLF 250
- BSV 250
- RSK 250
- YG 250
- VK 250
- LDC 250

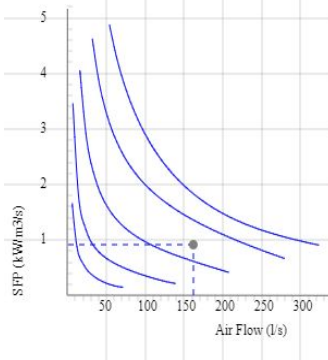
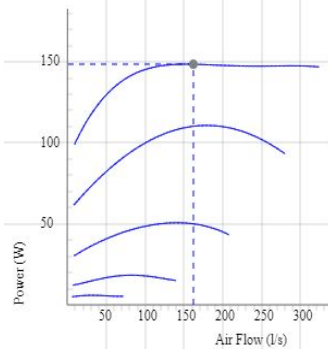
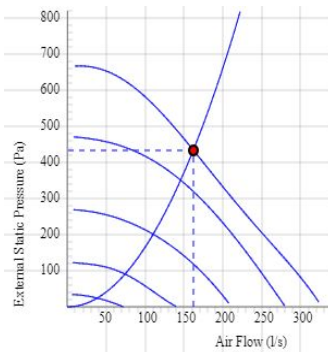

TECHNICAL DATA

7540820 LPKB 250 D1 EC-y2	
Voltage	230 V
Phase	1 ~
Frequency	50/60 Hz
Power	150 W
Current	1.22 A
Speed	2800 r.p.m.
Max. temperature of transported air	60 °C
Sound pressure level at 3 m	49 dB(A)
Weight	8.5 kg
Enclosure class	44 IP
Insulation class, motor	F
Duct connection	250 mm
Max. flow @ 0Pa	327 l/s
Max. pressure	673 Pa
Voltage range	200-277 V

SOUND DATA

	Flow (l/s)	L _{wa} tot dB (A)	63Hz	125Hz	250Hz	500Hz	1KHz	2KHz	4KHz	8KHz
5. Surrounding Lw dB(A) 10V	195	56	31	37	50	53	45	44	36	30
5. Outlet Lw dB(A) 10V	195	76	57	60	69	70	66	71	63	54
5. Inlet Lw dB(A) 10V	195	73	58	58	70	65	62	65	61	52
4. Inlet Lw dB(A) 8V	173	71	53	56	69	62	59	62	58	49
3. Inlet Lw dB(A) 6V	134	67	48	50	66	57	53	55	48	39
2. Inlet Lw dB(A) 4V	85	53	41	47	48	46	42	42	33	23
1. Inlet Lw dB(A) 2V	45	37	31	29	33	28	20	17	13	9

DIMENSIONS

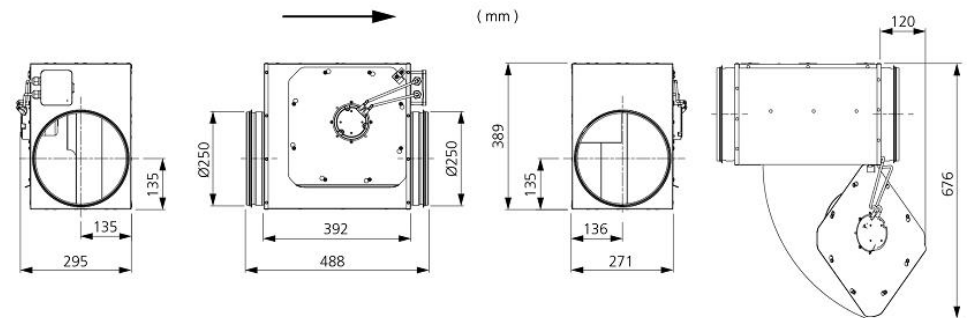

Voltage steps

1	2	3	4	5
2V	4V	6V	8V	10V