



TECHNICAL-OPERATING DOCUMENTATION

Bidirectional unit with heat recovery

- | | | |
|---|--|--|
| <input type="checkbox"/> PRANA-150
STANDART
(PRANA 150) | <input type="checkbox"/> PRANA-150
ERP LITE
(PRANA 150+) | <input type="checkbox"/> PRANA-150
ERP PRO
(PRANA 150++) |
| <input type="checkbox"/> PRANA-200G
STANDART
(PRANA 200G) | <input type="checkbox"/> PRANA-200G
ERP LITE
(PRANA 200G+) | <input type="checkbox"/> PRANA-200G
ERP PRO
(PRANA 200G++) |
| <input type="checkbox"/> PRANA-200C
STANDART
(PRANA 200C) | <input type="checkbox"/> PRANA-200C
ERP LITE
(PRANA 200C+) | <input type="checkbox"/> PRANA-200C
ERP PRO
(PRANA 200C++) |



Class II or double insulated electrical appliance



DESCRIPTION OF THE DEVICE

PRANA-150 and PRANA-200G belong to the category of innovative and reliable ducts aimed at creating and maintaining a healthy microclimate in premises of various functional purposes.

High energy efficiency and significant air exchange capabilities make it possible to apply these ventilation units for organizing domestic ventilation.

Technologically, the system is a monoblock with high-efficiency counter-current copper recuperator ready to use in accordance with the design and assembly tasks and conditions.

INTENDED USE

Ventilation units "PRANA-150", "PRANA-200C", "PRANA-200G" are intended for creation and maintenance of healthy microclimate in premises.

These systems are recommended for use in residential and public facilities (apartments, houses, office premises, educational establishments, kindergartens, etc.).

PRINCIPLE OF WORK

The basis of the technical solution for recuperation ventilation is the countercurrent, with a continuous thermal cycle, a copper heat exchanger, which makes it possible to form two different-directed airflows in the volume of one cylinder (Fig. 1).

Warm exhaust air that is removed from the room, passing through a copper heat exchanger transmits its warmth to the counter stream of fresh air from the outside.

The system allows recover heat, which contributes to increasing the overall recuperation rate and allows maintain the optimum humidity mode in the room. Taking into account that air streams are separated and regulated at levels "inflow" – "exhaust"», there is no mixing of different-directional air flows.

High velocity of the flow with sufficient heat transfer efficiency ensures removal of up to 90% moisture in a dispersed state, preventing its condensation and freezing of the heat exchanger at low ambient temperatures.

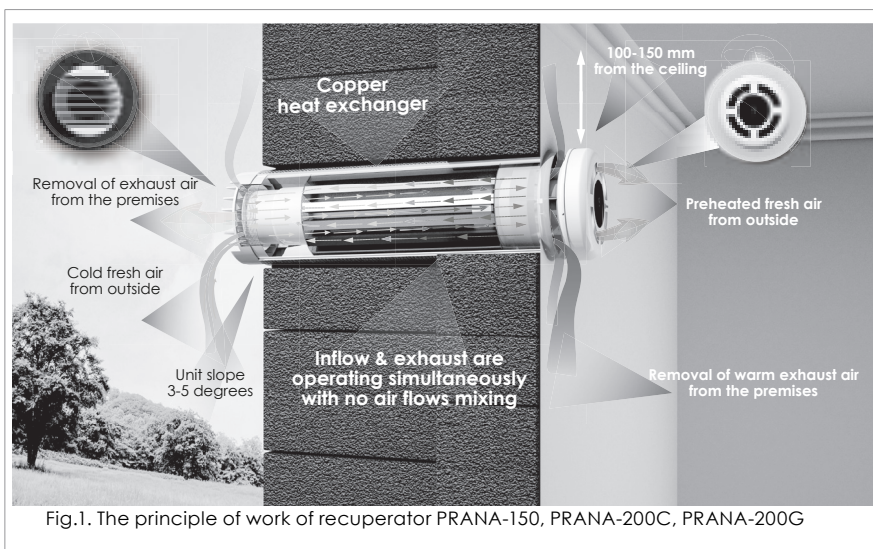

TECHNICAL DATA

	PRANA 150	PRANA 200G	PRANA 200C
Diameter of the working module, mm with thermal insulation, mm	150 160	200 210	200 210
Diameter of the mounting hole, mm Length of the working module, mm	≥162 ≥450	≥215 ≥440	≥215 ≥500
Recommended area of the premises, m ²	<60	<60	<120
Amounts of air exchange during recovery, m ³ /h; (the inflow and exhaust work simultaneously):			
-inflow	105	108	185
-exhaust	97	100	177
-night / minimal	12	12	21
-passive mode	6	10	10
Energy consumption, W * h: recuperator "mini-after-heating"	4-17 51	4-17 51	4-35 56
Recovery efficiency, %	95	96	93
Acoustic pressure from the product at a distance, dB (A):			
3m			
1m	14/52	13/50	15/54
Weight of the system in individual packing	≥ 4,3	≥ 5,8	≥ 6,0
The size of the packing box, mm (LxHxW)	≥750x210x210	≥750x260x260	≥750x260x260

Power supply: AC: 230 ± 10% V. Class of insulation: II. Degree of protection: IP 24.

Control: remote control, mobile application.

The body of the system is thermally insulated. Double protection against frontal blasting.

The function of "heating with minimally-raised temperature" and "freezing".

The established service life of the system: 10 years. The warranty period: 2 years.

The use of the system is designed for long-term operation at air temperature in the range from -30 °C to +50 °C.

ADDITIONAL FUNCTIONS

"Mini heating up" function

For additional comfort in equipping residential premises with ventilation units PRANA of residential-and-public and semi-industrial series, the function of air "Mini heating up" is provided for. It can be switched on by pressing the "Mini heating up" button on the remote control or in a mobile application (see the remote control manual included in the list of standard equipment).

After having activated the function of "Mini heating up", the temperature of the inflow air increases by 3-5 °C.

When the motors are switched off and the cover of the recuperator is open, this function additionally plays the role of an air heat curtain.

WARNING! DO NOT SWITCH ON "Mini heating up" , if the outside air temperature is +20 °C and above!

Function "Winter Mode"

Function "Winter Mode" is intended to prevent the icing of condensate drainage during the cold season or to freeze it if icing has occurred.

WARNING! To avoid icing and to ensure the system operates correctly at the minus temperature from the outside - the use of the Winter Mode is mandatory.

In mode «AUTO» after engine shutdown, «Winter mode» will work for 30 minutes to prevent icing in the system, which may result in reduced efficiency or condensate drainage complications.

Preheating element (additional option)

Recuperators that will be used in rooms with excessive humidity in the cold climate are recommended to be equipped with an additional heating element.

Passive mode

The operating mode of the ventilation system with the open lid of the recuperator and switched off motors. It lies in the movement of uncontrolled airflows through the recuperator due to the difference in pressure and temperature inside and outside the premises. It is allowed to use, when the difference between outside and inside temperatures is no more than 5 o C.

Defrosting

WARNING! In the cold season, the imper operation of the recuperator is likely to freeze it! When freezing, it is necessary to activate function «mini-heating up» with engine switched off for at least 60 minutes, and let it unfreeze, then turn on the recuperator to the required mode.

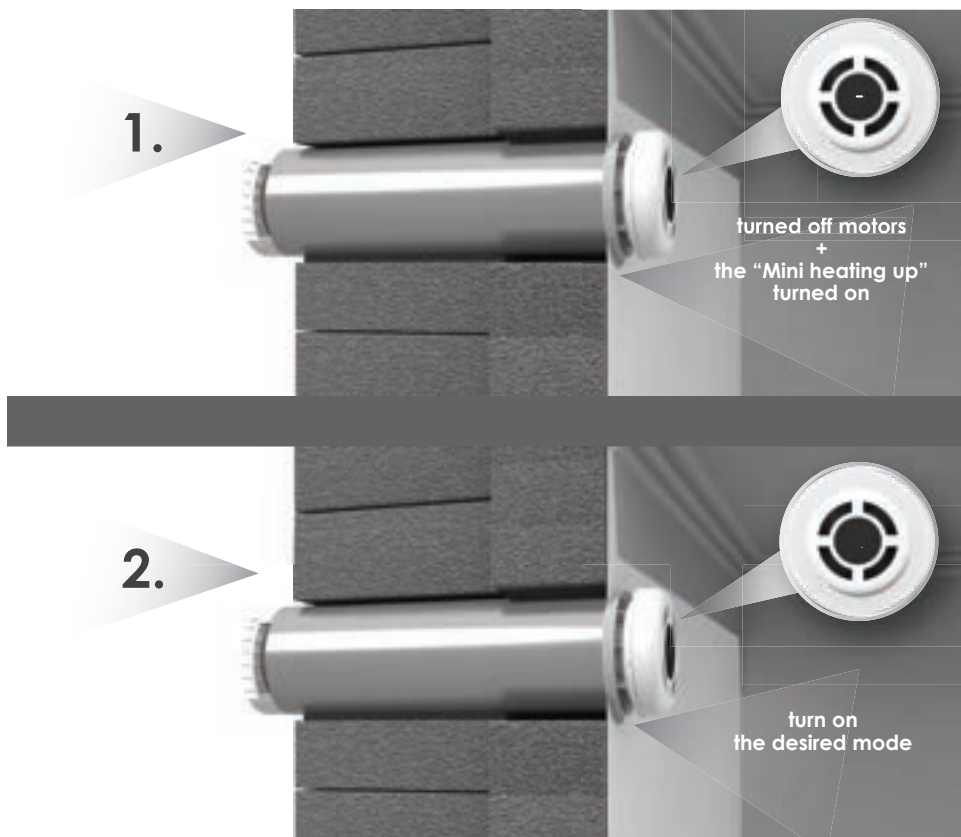

Fig. 2. Defrosting

OVERALL DIMENSIONS

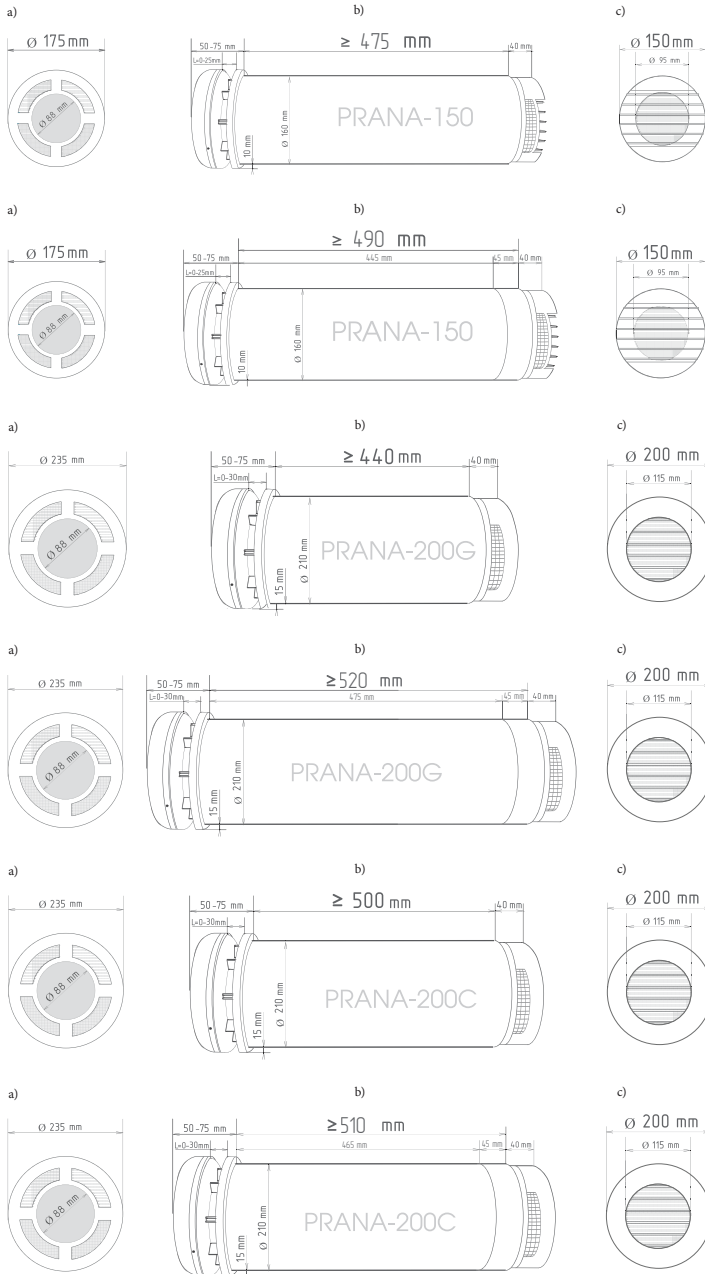

Fig. 3. The overall dimensions and the dimensions of ventilation units "PRANA-150", "PRANA-200G", "PRANA-200C":

- a) the ventilation grid and air intake in the premises;
- b) monoblock, side view;
- c) the ventilation grid and air intake from the outside.



INSTALATION

Bidirectional ventilation unit with heat recovery "PRANA" is a monoblock ready for use in accordance with design and assembly tasks and conditions.

The system is mounted in a hole of the appropriate diameter in the upper part of the wall adjoining the outside, at a distance of no less than 100-150 mm from the ceiling or walls. The through hole should be a slope of 3-5 degrees towards the outside. The operating module of the ventilation unit is mounted in the hole using a seal (Fig. 4).

The length of the working module should correspond to the thickness of the wall in which the installation will be carried out. In order to ensure the normal operation of the system, it is necessary that its body facing the the outside extends beyond the wall by 1-2 cm to the beginning of the air intake (Fig. 4).

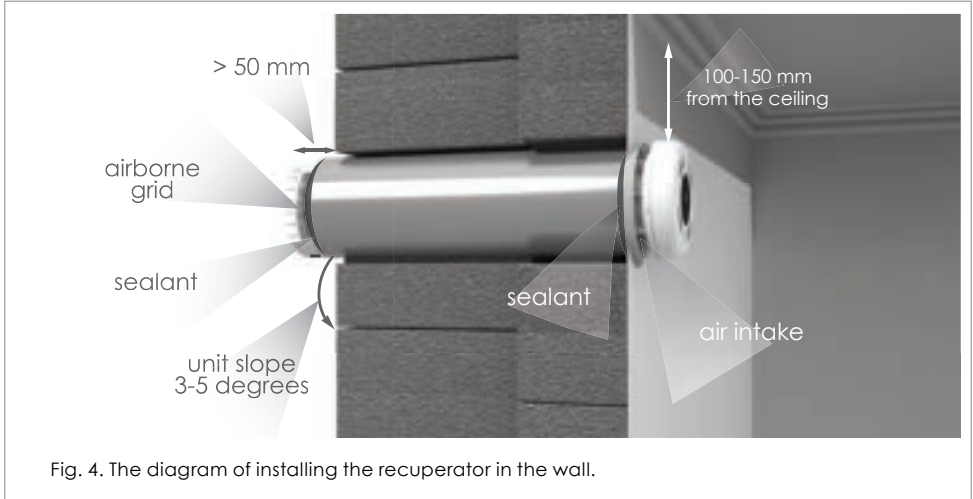

Other preparatory works:

- preparation of the hole for installing the switch and preparation of the grooves for the installation of the electrical supply network between the system, the switch and the place of connection of the system to the power supply source.



CONNECTING TO THE ELECTRICAL SUPPLY NETWORK



IMPORTANT:
READ THESE INSTRUCTIONS BEFORE COMMENCING THE INSTALLATION

DO NOT install this duct in areas where the following may be present or occur:

- Excessive oil or a grease laden atmosphere.
- Corrosive or flammable gases, liquids or vapors.
- Ambient temperatures higher than 40°C or less than -5°C.
- Possible obstructions which would hinder the access or removal of the recuperator.

SAFETY AND GUIDANCE NOTES

A. All wiring to be in accordance with the current I.E.E. Regulations, or the appropriate standards of your country and **MUST** be installed by a suitably qualified person.

B. The recuperator should be fitted with a local isolator switch capable of disconnecting all poles, having a contact separation of at least 3mm.

C. Ensure that the mains supply (Voltage, Frequency, and Phase) complies with the rating label.

D. The recuperator should only be used in conjunction with fixed wiring.

E. The recuperator should not be used where it is liable to be subject to direct water spray for longed periods of time.

F. Stationary appliances not fitted with means for disconnection from the supply mains having a contact separation in all poles that provide full disconnection under over voltage category III, the instructions state that means for disconnection must be incorporated in the fixed wiring in accordance with the wiring rules.

Connecting the recuperator, controlling the system from the remote control.

The recuperator **MUST** be isolated from the power supply during the installation/or maintenance

Fig. 6

220-240V
~50Hz

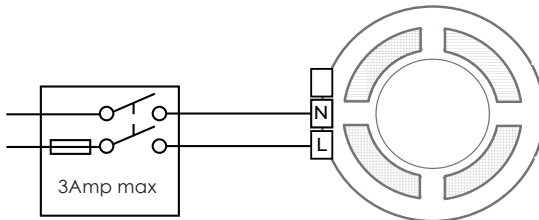

WARNING! Ensure that the electric power supply is really switched off using appropriate test equipment!

- To connect ventilation unit, follow wiring diagram Figure 6
- The ventilation unit should only be used in conjunction with fixed wiring
- All electrical cables used in the installation should have the cross-section of 0.5-0.75 mm². The operation of the system is controlled using a remote control or mobile application that controls the operation of the fans installed in the body of the ventilation system (it turns on, regulates and turns off).
- Cable entry can only be made from the rear of the unit. Shorten the electric cable, if necessary, to a length that is convenient for electrical connection.
- The ventilation unit is suitable for connection to 220-240V 50 Hz supply
- The ventilation unit is class II double insulated duct and must not be earthed

The PRANA 150 / 200G / 200C recuperators are adapted to connected voltage in an automatic mode, without the use of software. This significantly reduces the noise indicators of the equipment and allows ensure the noise characteristics of the ventilation system declared in the technical passport.



START-UP

The first start-up of the device should be carried out by a specialist who has theoretical knowledge and has practical skills in the electrical installation of this ventilation unit.

Before starting-up, it is necessary to check:

- all connections have been made correctly and ensure all terminal connections are securely fastened (according to Fig. 6);
- if the air in is open and impeller rotates and is free from obstructions ;
- if the ventilation unit is functioning perly.

WARNING! Before turn on the device, open the air intake as indicated in the photo below:

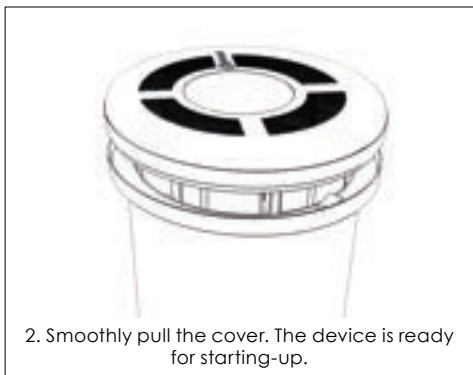

OPERATION

During operation, it is necessary to periodically check:

- the quality of function of the fans;
- the correspondence of the graphic symbols of the indication;
- correct operation of the device in accordance with the control devices.

The device must be turned off in case of:

- excessive oscillations and noise;
- damage to the elements of the device body;
- damage to the insulation of the electric cable;
- damage to the elements of automation;
- the temperature of the outside air is below $-30\text{ }^{\circ}\text{C}$.

ADAPTATION TO THE ELECTRICAL SUPPLY NETWORK

The PRANA 150 / 200G / 200C recuperators are adapted to an existing electrical supply network automatically, without the use of software. It significantly reduces the noise indicators of the equipment and allows ensure the noise characteristics of the ventilation unit declared in the technical passport.

MAINTENANCE

The maintenance consists in periodic (recommended 1-2 times a year) and preventive inspection of surfaces of the fans and the heat exchanger and, if necessary, in cleaning them. The cedure for disassembling / assembling the device for / after cleaning:

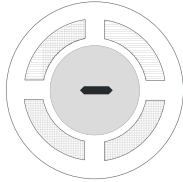

1. Press the "Turn off" button on the remote control. Turn off the ventilation unit.

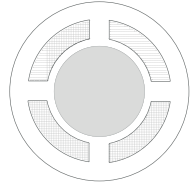
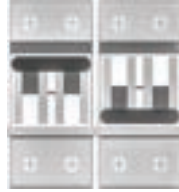

2. De-energize the device.

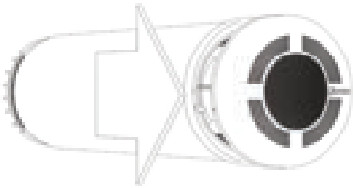

3. Open the lid of the recuperator.



4. Turn the fasteners of the lid and remove it.

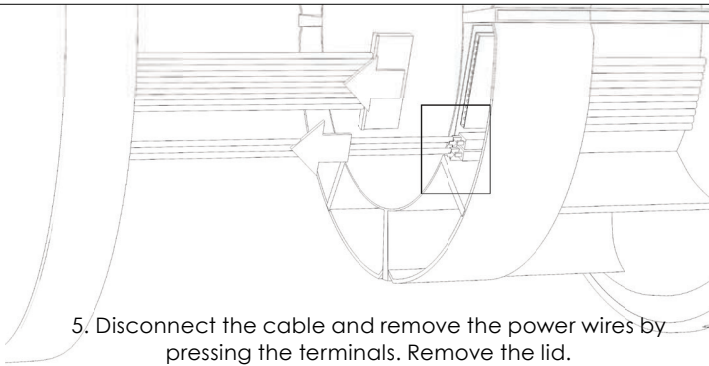

5. Disconnect the cable and remove the power wires by pressing the terminals. Remove the lid.

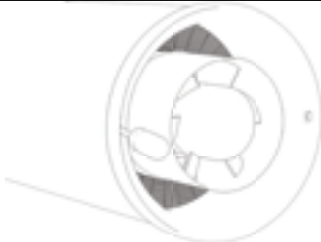

6. Unscrew the self-tapping screws through special openings. Remove the flange.



7. Extract the heat exchanger and fans from the body.

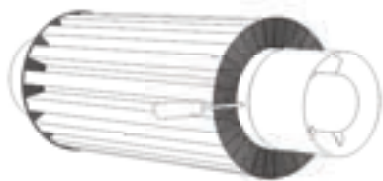

8. Unscrew the self-tapping screws.
Remove the fans on both sides.

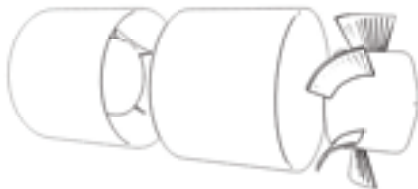

9. Remove the blades from the fan housings
and clean them in a dry manner.



10. Clean the heat exchanger in adry or, if
necessary, in a wet manner.

WARNING!

Before rinsing or wet cleaning of the
heat exchanger, make sure that all
the electrical components and parts
are removed from the heat exchanger
(except for the components of
“Mini heating up” and «heating the
condensate drainage»).

ASSEMBLY IN THE REVERSE ORDER

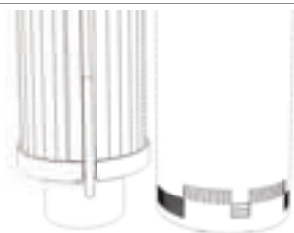

11. The drain in the heat exchanger and
the body must coincide and be below
during the installation.



12. The flange must be installed correctly;
the larger trusion of the should be below.

QUALITY

The technological cess vides for 100% inbound quality control for all components, as well
as double 100% inbound control after their manufacture and 24-hour run in the maximum
performance mode.

TRANSPORTATION AND STORAGE RULES

Transportation and storage of the ducts in individual packing boxes is ensured in a horizontal
position.

Keep the recuperator in the factory packaging under the cover or (in enclosed space) with
relative humidity of air of no more than 70% and air temperature from -20°C to + 40°C.

SCOPE OF DELIVERY

- Ventilation unit.
- Technical - operation documentation.
- Technical (warranty) card.
- Remote control.
- Manual for the remote control.
- Packing box

SAFETY REQUIREMENT

All electrical installation works (maintenance) must be carried out only by a qualified specialist with a category of admission to such works.

Ensure that during installation, the visions, mechanical and electrical installation rules and norms valid in the country, in which the installation is carried out, are observed.

WARNING! All installation and electrical works relating to the connection (maintenance) are carried out only after the device is disconnected from the electrical supply network.

WARNING! Do not operate the ventilation unit, if there is a threat that foreign objects may enter the inflow part of the body, which objects may jam or damage the impeller of any of the two fans.

WARNING! Do not operate the ventilation unit in premises, where the air contains aggressive substances and does not correspond to the working temperature regime.

After commissioning, the ventilation unit must comply with the visions of the following directives:

- Directive 2014/35 / EU. Low Voltage Directive (LVD);
- Directive 2006/42 / EU. Safety of Machinery mechanisms;
- Directive 2004/108 / EU. Electromagnetic Compatibility (EMC);
- Directive 2011/65 / EU. Restriction of Hazardous Substances (RoHS);
- Directive 2009/128 / EU. Ecodesign (ErP);

