ZRS Smoke gas fan



Table of contents

1	Introduction	1	13	EU Declaration of Conformity.....	14
1.1	Product description	1	14	UK Declaration of Conformity.....	15
1.2	Intended use	1			
1.3	Document description.....	1			
1.4	Product overview.....	1			
1.5	Name plate	1			
1.5.1	Type designation	2			
1.6	Product liability.....	2			
2	Safety	2			
2.1	Safety definitions.....	2			
2.2	Safety instructions	2			
2.3	Personal protective equipment	3			
3	Transportation and storage	3			
4	Installation.....	4			
4.1	To do before the installation of the product.....	4			
4.2	To Install the product	4			
5	Electrical connection.....	5			
5.1	To do before the electrical connection	5			
5.2	To connect the product to the power supply	5			
5.3	Speed controller for AC motors.....	5			
5.4	To install motor protection for AC motors	5			
6	Commissioning	6			
6.1	To do before the commissioning.....	6			
6.2	To do the commissioning.....	6			
7	Operation.....	6			
7.1	To start a product with an AC motor	6			
7.2	To stop the product	6			
7.2.1	To stop the product in an emergency.....	6			
8	Maintenance.....	7			
8.1	Maintenance schedule.....	7			
8.2	To clean the product.....	7			
8.3	Spare parts	7			
9	Troubleshooting.....	8			
10	Disposal.....	9			
10.1	To disassemble and discard the parts of the product.....	9			
11	Warranty	9			
12	Technical data	10			
12.1	Technical data overview.....	10			
12.2	Product dimensions	10			
12.3	Wiring diagrams	11			
12.3.1	Wiring diagrams for ZRS fans	11			
12.3.2	Wiring diagrams for speed controller for AC motors	11			

1 Introduction

1.1 Product description

The product is a smoke gas fan with an AC motor.

The product is not supplied with an external speed control or power switch.

1.2 Intended use

The product is intended to prevent insufficient draft from stoves, ovens and fire places. The maximum temperature of transported air is 200 °C.

1.4 Product overview

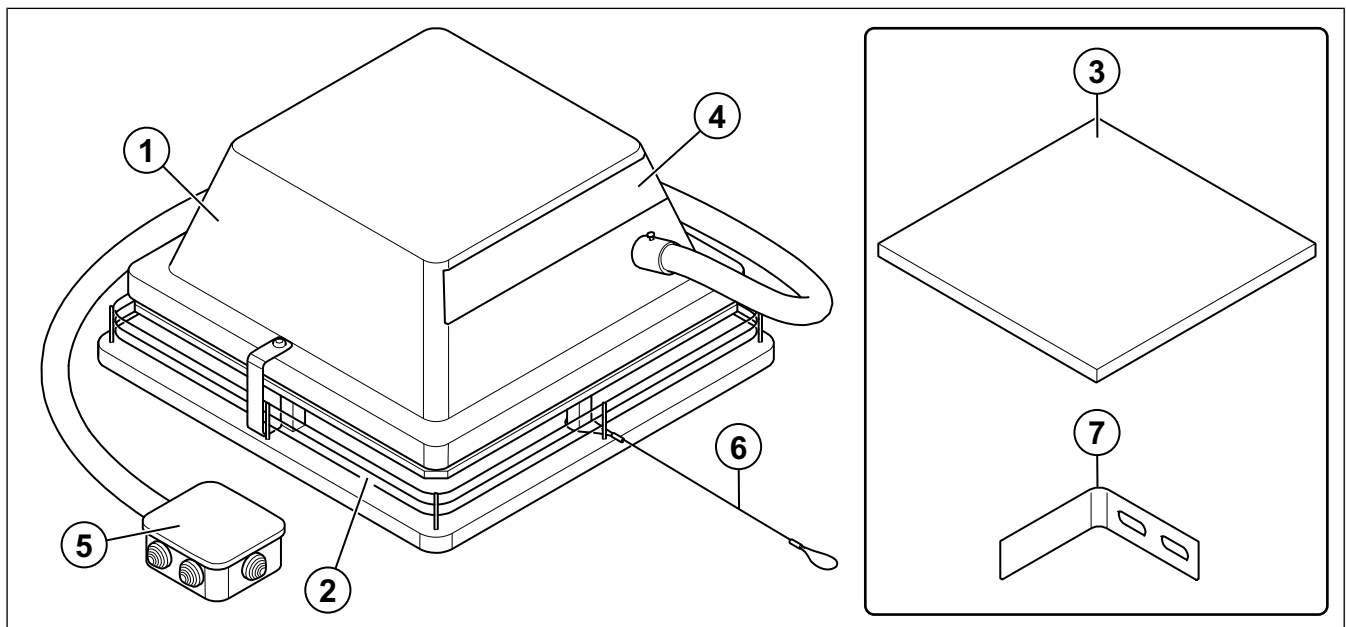

- | | |
|--|-------------------|
| 1. Casing | 5. Connection box |
| 2. Protection grille | 6. Steel wire |
| 3. Insulation carpet | 7. Steering rods |
| 4. Name plate with airflow direction arrow | |

1.5 Name plate

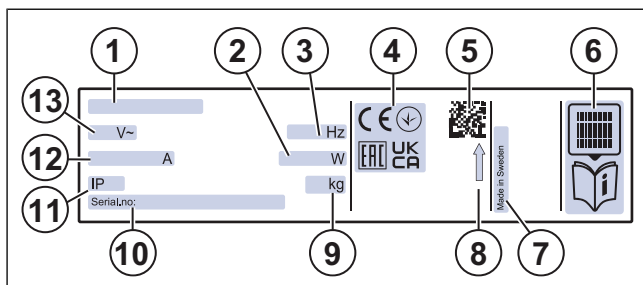

The product is not applicable for transportation of air that contains explosive, flammable or aggressive media. The product is not applicable for locations where there is a risk of explosion.

1.3 Document description

This document contains instructions for installation, operation and maintenance of the product. The procedures must be done by approved personnel only.

Speak to Systemair for more information on how to install the product in different installation locations.

1. Type designation: Product name, dimension and motor type. Refer to [1.5.1 Type designation](#).
2. Input power, W
3. Frequency, Hz
4. Certifications
5. Scannable code¹
6. Find more information about the product on the Systemair documentation portal¹
7. Country of production
8. Airflow direction arrow
9. Weight, kg
10. Serial number: part number/production number/production date
11. IP class, enclosure class
12. Current, A
13. Voltage, V

1. Use a mobile device to scan the scannable code and go to the Systemair documentation portal for more documentation and document translations.

Note:

The data on the name plate applies to “standard air” that is specified in the standard ISO5801.

1.5.1 Type designation

Product name	ZRS
Dimension	170
	180
Motor type	AC, 1–phase, 230 V

1.6 Product liability

Systemair is not liable for damages that the product causes in these conditions:

- The product is incorrectly installed, operated or maintained.
- The product is repaired with parts that are not original spare parts from Systemair.
- The product is used together with accessories that are not original accessories from Systemair.
- The product is used without motor protection.

2 Safety**2.1 Safety definitions**

Warnings, cautions and notes are used to point out specially important parts of the manual.

**Warning**

If you do not obey these instructions, there is a risk of death or injury.

**Caution**

If you do not obey these instructions, there is a risk of damage to the product, other materials or the adjacent area.

Note:

Information that is necessary in a given situation.

2.2 Safety instructions**Warning**

Read the warning instructions that follow before you do work on the product.

- Read this manual and make sure that you understand the instructions before you do work on the product.
- Obey local conditions and laws.
- The ventilation contractor and the operator are responsible for correct installation and intended use.
- Keep this manual at the location of the product.
- Do not install or operate the product if it is defective.
- Do not remove or disconnect safety devices.
- Make sure that you can read all warning signs and labels on the product when it is installed. Replace labels that have damage.
- Only permit approved personnel to work on the product and to be in the adjacent area during all work on the product.
- Make sure that you know how to stop the product quickly in an emergency.
- Use applicable safety devices and personal protective equipment during all work on the product.
- Before you do work on the product, stop the product and wait until the fan impeller stops. Make sure that there is no voltage on the motor terminals.
- If the maintenance is not correctly and regularly done, there is risk of injury and damage to the product.
- Only do the maintenance as given in this manual. Speak to Systemair technical support if other servicing is necessary.
- Always use spare parts from Systemair.
- Sound levels exceeding 70 dB(A) may occur depending on model and size. Visit www.systemair.com for more detailed information about your product.
- The product is not to be used by persons, including children, with reduced physical, sensory or mental

capabilities, or lack of experience and knowledge, unless they have been given supervision or instruction.

- Do not allow children to play with the device.

2.3 Personal protective equipment

Use personal protective equipment during all work on the product.

- Approved eye protection
- Approved protective helmet
- Approved hearing protection
- Approved protective gloves
- Approved protective shoes
- Approved work clothing

3 Transportation and storage



Warning

Make sure that the product does not become damaged or wet during transportation. A damaged or wet product can cause fire or electric shock.

- Before you move the product to the installation location, examine the packaging for damages.
- Do not move the product by the cables, terminal box, fan impeller, protection grille, inlet cone or silencer.
- If lifting equipment is used, make sure that the lifting equipment can hold the weight of the product. Refer to the name plate for information. Do not lift the product by the packaging.



Warning

Do not walk below a lifted product.

- Keep the correct side of the packaging up during transportation. Refer to the arrows on the packaging.
- Load and unload the product carefully.
- Keep the product in a dry and clean location during storage. Make sure that the ambient temperature during storage is between -10 and $+30$ °C. A stable ambient temperature prevents damage from condensation.
- Keep the product in storage for maximum 1 year.

4 Installation

4.1 To do before the installation of the product

- Use installation material with fire resistance rating for the installation location.
- Examine the packaging for transportation damage and remove the packaging from the product carefully.
- Examine the product and all components for damage.
- Make sure that the motor effect and the fan performance agrees with the expectations at the installation location.
- Make sure that the information on the name plate and the motor name plate agrees with the operation conditions.
- Install the product in a location where there is space for commissioning, troubleshooting and maintenance.
- Make sure that the installation location is clean and dry, for full safety during electrical work.
- Make sure that the installation surface has sufficient capacity to hold the weight of the product.
- Refer to the airflow direction arrows on the name plate or on the product to install the product in the correct position.
- Make sure that all cable glands are tight against the cables to prevent leaks.

4.2 To Install the product

Note:

Make sure that the installation location has space for maintenance.

Note:

Install the product so that unwanted vibrations are not transmitted to duct systems or roof beams.

Note:

The product must be installed horizontally.

Note:

Obey local laws and regulations for installation of the smoke gas fan.

- 1 Put the supplied insulation carpet on top of the chimney or duct system.

- 2 Cut a hole in the insulation carpet. Make sure that the hole has the same dimension as the inlet cone of the fan.

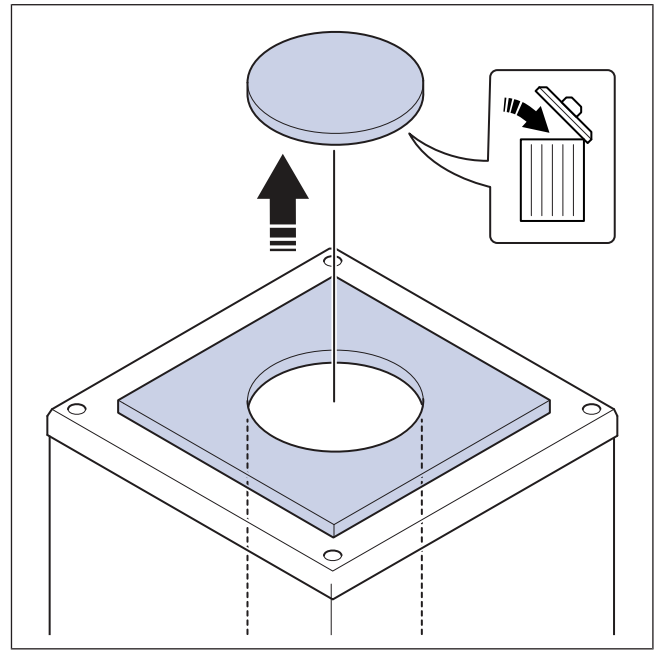

- 3 Install the 4 adjustable steering rods in the holes in the bottom plate of the fan. Use the supplied screws and nuts.

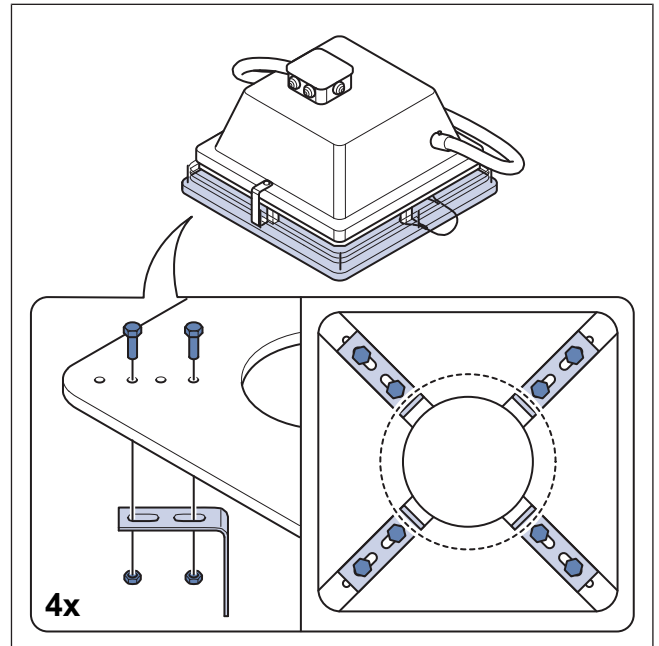

- 4 Push the fan and steering rods into the chimney. It is not necessary to attach the fan with screws in the chimney, the steering rods keeps the fan in position.

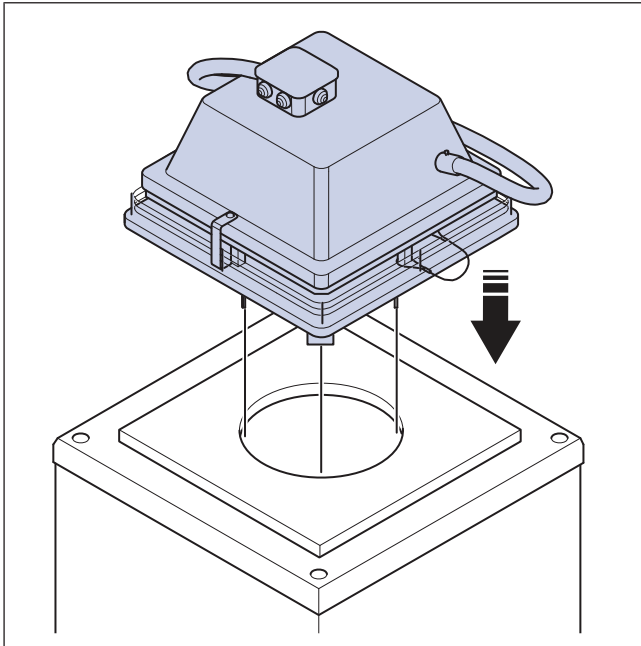

- 5 Attach the supplied steel wire. The steel wire keeps the product on the roof when it is temporarily lifted away from the chimney during chimney sweeping. The product is not supplied with screws and plug to attach the steel wire.

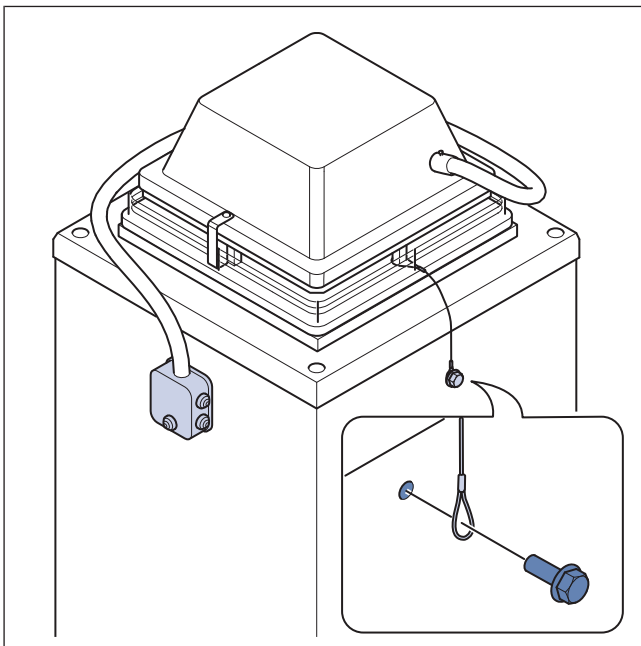

- 6 Connect the mains supply to the connection box of the product. Refer to [12.3 Wiring diagrams](#).

Note:

The cable has a steel housing that can discolour over time as it weathers in. The coloring of the steel housing will not decrease the protection of the cable.

5 Electrical connection

5.1 To do before the electrical connection

- Make sure that the electrical connection agrees with the product specification on the motor name plate.
- Make sure that the environment for electrical connection is clean and dry.
- Make sure that the wiring diagram that is included with the supply of the product agrees with the terminals in the connection box.

5.2 To connect the product to the power supply

- Complete the electrical connection for the motor. Refer to the motor wiring diagram that is included with the product.
- Make sure that the cross section of the protective earthing is equal to or larger than the cross section of the phase conductor.
- Install a circuit breaker in the permanent electrical installation, with a contact opening of a minimum 3 mm at each pole.
- If a residual current device (RCD) is installed, make sure that it is an all-current sensitive RCD. Consider if the product has a frequency converter or uninterruptible power supply (UPS).

5.3 Speed controller for AC motors

Note:

The speed controller alternatives are different for different motor types. Make sure that your motor is compatible with the speed controller type before you use it.

The speed can be controlled by voltage reduction using a transformer. It is also possible to control the fan speed with frequency converter if the installed frequency converter has built in all-pole sine filter and shielded cables are not needed.

5.4 To install motor protection for AC motors

- If the product has an built in motor protection, reset by disconnecting the product from power for 60 seconds.
- If the motor has temperature monitors such as thermal contacts (TK) or thermistors lead out into the terminal box, these must always be connected in the control circuit using appropriate motor protection.
- Make sure that an overheated motor cannot start again automatically when it becomes cool.
- Install the motor cables and the temperature monitor apart.
- If the motor does not have temperature monitors, install a motor protection switch.

6 Commissioning



Caution

- If strong vibrations occur during commissioning, immediately increase or decrease the fan speed until the vibrations are decreased. Continuous strong vibrations can cause damage to components.
- Do not increase the fan speed to a higher rpm value than the maximum value that is given on the name plate.

The commissioning report is found at www.systemair.com.

6.1 To do before the commissioning

- Make sure that the installation and electrical connection are correctly done.
- Visually examine the product and accessories for damage.
- Make sure that the safety devices are correctly installed.
- Make sure that there are no blockages in the air inlet and the air outlet.
- Make sure that installation material and unwanted objects are removed from the product and the ducts.

6.2 To do the commissioning

- 1 Set the installed safety switch in the OFF position.
- 2 If it is possible to get access to the fan impeller, do the steps that follows:
 - a. If it is necessary, remove parts of the installation.
 - b. Turn the fan impeller by hand and make sure that it turn easily.
 - c. Record the result in the commissioning report.
- 3 Make sure to turn the product in a direction that agrees with the related arrow on the product.
 - a. Record the result in the commissioning report.
- 4 If you removed parts of the installation to get access to the fan impeller, install the removed parts again.
- 5 Set the installed safety switch in the ON position.
- 6 Start the product.
- 7 Set the minimum operation speed.
- 8 Increase the operation speed gradually to the maximum operation speed.
 - a. Examine the vibrations in the casing and the bearing areas at all speed levels.
 - b. Make sure that the vibrations agree with the specifications in ISO 14694.
 - c. Make sure that none of the speed levels cause unwanted noise in the product.
 - d. Record the result in the commissioning report.
- 9 Record the necessary data in the commissioning report.

7 Operation

7.1 To start a product with an AC motor

- 1 Set the installed safety switch in the ON position.
- 2 Install the external speed controller. Refer to the instruction manual for the installed speed controller.

7.2 To stop the product

- 1 Set the installed speed controller in the OFF position. Refer to the instruction manual for the installed speed controller.
- 2 Set the installed safety switch in the OFF position.

7.2.1 To stop the product in an emergency

- Set the installed safety switch in the OFF position.

8 Maintenance



Warning

Set the installed safety switch in the OFF position before you do the maintenance unless the instructions tell you differently. Make sure that the safety switch is not accidentally set in the ON position.

8.1 Maintenance schedule

The intervals are calculated from continuous operation of the product.

Maintenance task	Usual operation conditions		Unusual operation conditions. ¹		
	Each 6 months	Each year	Each 3 months	Each 6 months	Each year
Visually examine the product and its components for damage, corrosion and dirt.		X		X	
Examine the fan impeller for damage and imbalance.		X		X	
Clean the product and the ventilation system.	X		X		
Do a check of all fasteners and make sure that they are fully tightened.		X			X
Make sure that the product and its components are correctly operated.	X			X	
Measure the power consumption and compare the result with the information on the name plate.		X		X	
If vibration dampers are installed, make sure that they operate correctly and examine them for damage and corrosion.		X			X
Make sure that the electrical protective equipment and the mechanical protective equipment operates correctly.		X			X
Make sure that you can read the name plates of the product.		X		X	
Examine all cable connections for damage. Make sure that the cable glands are tight against the cables.		X			X
If flexible connections are installed, examine them for damage.	X			X	

1. The unusual operation conditions are classified as follows: If a stable ambient temperature is higher than 30 °C or lower than -10° C, if the temperature changes are large or if very contaminated air is transported.

8.2 To clean the product



Caution

- Do not clean the product with a high-pressure washer.
- Do not clean the product with steel brushes or sharp objects.
- Do not bend the fan impeller blades.
- Be careful not to move the balance weights on the fan impeller.

- Remove dirt from the fan and the duct.
- If access to the fan impeller is possible, clean the fan impeller with a moist cloth or soft brush.

8.3 Spare parts

- When you send an order for spare parts, include the serial number of the product. The serial number is found on the name plate.
- For more information about spare parts, contact technical support.
- Always use spare parts from Systemair.
- To find spare parts, refer to the scannable code on the name plate.

9 Troubleshooting

Note:

If you cannot find a solution to your problem in this section, speak to Systemair technical support.

Problem	Cause	Solution
The product does not operate smoothly.	The fan impeller is not correctly balanced.	Speak to Systemair technical support.
	There is dirt on the fan impeller.	Clean the fan impeller carefully. Refer to 8.2 To clean the product .
	The fan impeller has damages or deformations because the transported air contains aggressive media.	Speak to Systemair technical support.
	The fan impeller does not turn in the correct direction.	Make sure that the electrical connection is correctly done.
	The fan impeller has deformations because of too high temperatures.	<ul style="list-style-type: none"> • Replace the fan impeller. • Make sure that the temperature of the transported air is not higher than the value on the name plate.
	There are unusually strong vibrations in the product or the duct system.	Make sure that the product is correctly installed. Do a check of the duct system.
	The product is operated in a resonant frequency range.	Increase or decrease the fan speed until the product operates smoothly. Refer to 6 Commissioning .
The air output is not sufficient.	The fan impeller does not turn in the correct direction.	Make sure that the electrical connection is correctly done.
	The electrical connection is not correctly done.	Make sure that the electrical connection agrees with the wiring diagrams.
	The air pressure is too low because of incorrect installation.	Do the necessary changes in the duct system and installed components to increase the air pressure. Refer to 6 Commissioning .
	The airflow shutters are closed or not fully open.	Adjust the airflow shutters.
	There is blockage in the air inlet or the duct system.	Remove the blockage.
	The product is not applicable for the installation location.	Make sure that the product is applicable for the installation location.
There is unusual noise when the product starts or operates.	There is strain in the connections of the duct system.	Loosen the connections, align the parts of the duct system correctly and tighten the connections.
Thermal contacts, PTC or resistors are released.	The fan impeller does not turn in the correct direction.	Make sure that the electrical connection is correctly done.
	The motor is overheated.	<ul style="list-style-type: none"> • Do a check of the motor cooling impeller. • If it is possible, measure the resistance to do a check of the motor winding.
	The capacitor is not connected or not correctly connected.	Connect the capacitor correctly. Refer to the included motor wiring diagram.
	There is blockage in the motor.	Speak to Systemair technical support.

Problem	Cause	Solution
The fan speed does not get the nominal value.	Defective motor winding.	If it is possible, measure the resistance to do a check of the motor winding.
	The speed control is not correctly set.	Set the speed control correctly.
	The fan impeller cannot turn freely because of mechanical blockage.	Remove the blockage.
The motor does not rotate.	A component in the power supply is defective.	Do a check of the power supply. Replace defective components and connect the power supply again.
	The electrical connection is not correctly done.	Make sure that the electrical connection agrees with the wiring diagrams.
	The motor protection is released because the motor is overheated.	Let the motor become cool. Reset the motor protection. Find the cause of the overheated motor.
The electronic components or the motor is overheated.	The motor is overloaded or the ambient temperature is too high.	Let the motor become cool. Reset the motor protection. Find the cause of the overheated motor.
	The motor is overloaded.	Make sure that the product is applicable for the installation location.
	The ambient temperature is too high.	Make sure that the product is applicable for the installation location.
	The cooling of the product is not sufficient.	Make sure that the space around the motor is sufficient to keep the temperature down.

10 Disposal

The product follows the WEEE directive. This symbol on the product or the packaging of the product shows that this product is not domestic waste. The product must be recycled at an approved disposal location for electrical and electronic equipment.

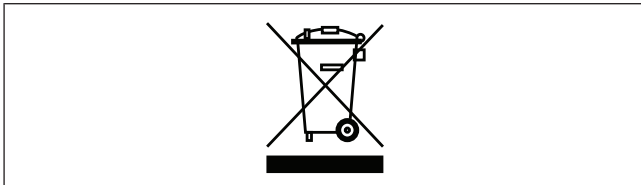

10.1 To disassemble and discard the parts of the product

- 1 Disconnect and disassemble the product in the opposite sequence of electrical connection and installation.
- 2 Recycle the product parts and the packaging at an applicable disposal location.
- 3 Obey the local and national requirements for disposal.

11 Warranty

For warranty claims, send a written maintenance plan and the commissioning report to Systemair. The warranty is only applicable for these conditions:

- The product is correctly installed and operated.
- Motor protection is used.
- The instructions in the data sheets are obeyed.
- Maintenance instructions are obeyed.
- A product that is not operated continuously is operated for a minimum of 1 hour each month.

12 Technical data

12.1 Technical data overview

Max. temperature of transported air, °C	200
Max. ambient temperature, °C	Refer to the data sheet in the online catalogue at www.systemair.com .
Sound pressure, dB	
IP class	
Voltage, current, frequency, enclosure class, weight	Refer to the name plate. Refer to 1.5 Name plate for more information.
Motor data	Refer to the motor name plate or the technical documentation from the motor manufacturer.

12.2 Product dimensions

Note:

If the unit of measure is not specified, the dimensions are given in millimetres.

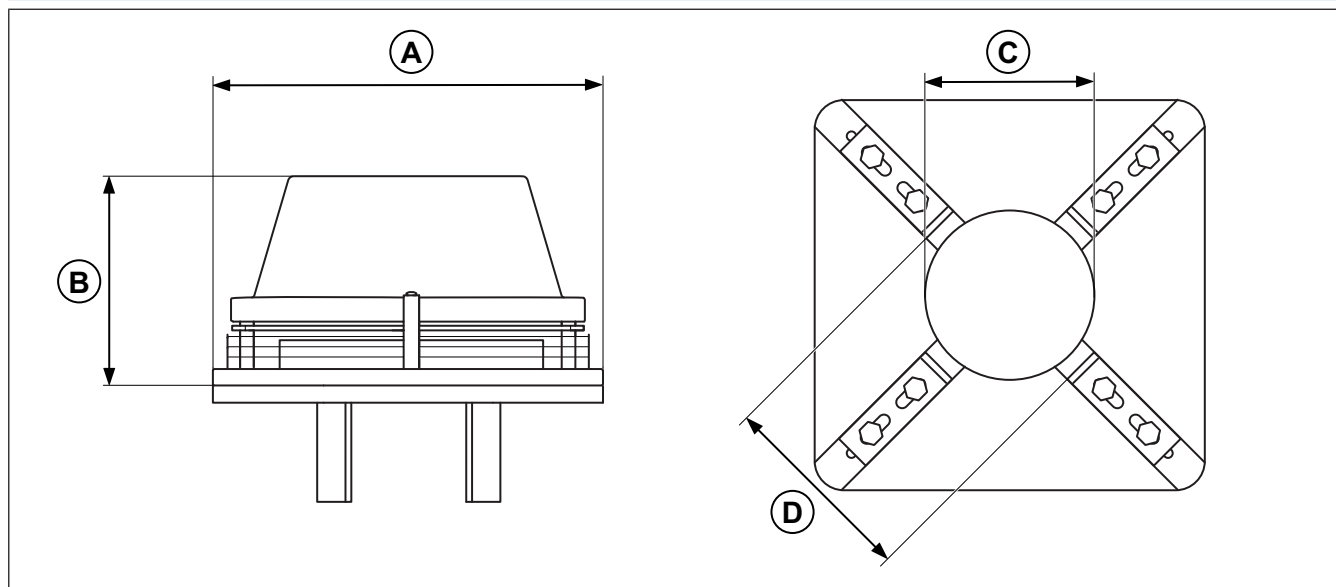

	A	B	ØC	D (max/min)
ZRS 170-180	300	180	132	100/230

12.3 Wiring diagrams

Abbreviation in wiring diagram	Cable colour
RD	Red
YE	Yellow
BU	Blue
WH	White
GN	Green
BN	Brown
BK	Black
GR	Grey
GY	Green/Yellow

12.3.1 Wiring diagrams for ZRS fans

ZRS fans	1-phase 230 V
ZRS 170-180	

12.3.2 Wiring diagrams for speed controller for AC motors

Note:

The selection of electrical accessories must be done in line with the technical parameters of the product.

RE	
Manual 5-step transformer.	

- A. Relay connection. There is always 230 V between ~ and N when the transformer knob is in one of the positions 1-5.
- B. Mains supply
- C. Earth
- D. Fan

REE — Thyristor	
REE 1 and REE 2 - Surface mounting or with flush mounting casing included.	
REE 4 - Surface mounting.	
Note:	
Starting currents must be considered when you select the speed controller type. Products that are used with this speed controller must have a built-in overheating protection and must be designed for thyristor speed control.	

- L: the connection with cutting function on the speed control.
- (L): the connection without cutting function.

REU	
Manual 5-step transformer for high/low speed operation. Used together with a change-over contact, for example a timer or a thermostat.	

- | | |
|--|---|
| <ol style="list-style-type: none"> 1. External change-over contact 2. Left selector switch 3. Right selector switch | <ol style="list-style-type: none"> A. Fan B. Earth C. Mains supply |
|--|---|

RTRE	
Manual 5-step transformer with motor protection.	

- A. Relay connection. There is always 230 V between ~ and N when the transformer knob is in one of the positions 1–5.
- B. Mains supply
- C. Earth
- D. Fan
- E. Thermostat
- F. Motor protection. If the motor protection is not in use, Tk must be looped together.

FRQ5S-E-6A

Frequency converter with built-in all-pole sine filter and 5-step switch.

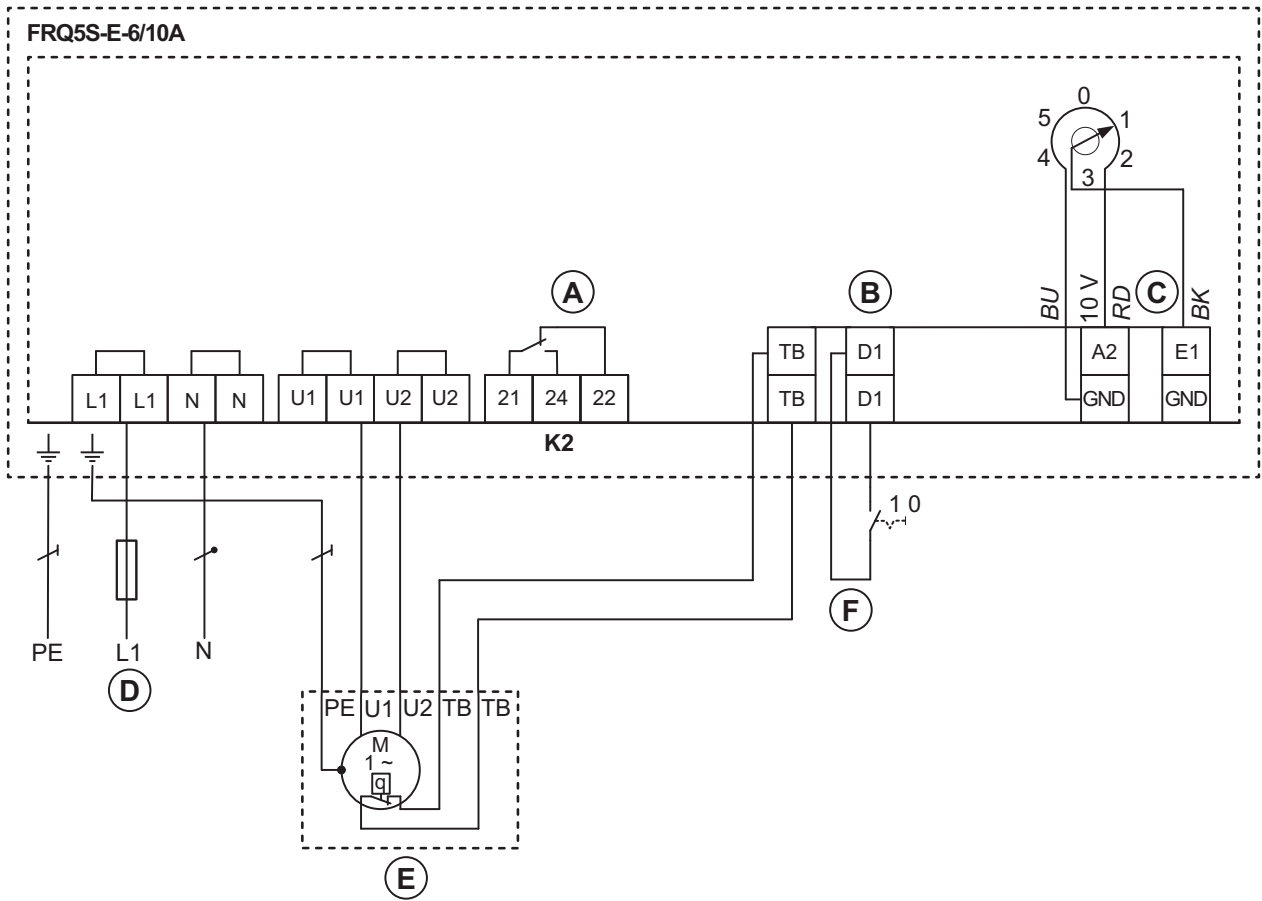

- A. Contact rating, maximum AC 250 V/2 A
- B. Digital In 1
- C. Analog In 1
- D. Mains supply, 1-phase 208...277 V, 50/60 Hz
- E. Motor with internal thermal contacts
- F. OFF/ON

13 EU Declaration of Conformity

We, the manufacturer

Manufacturer	Systemair Sverige AB
Address	Industrivägen 3 739 30 Skinnskatteberg Sweden

declare under our sole responsibility that the products

Machine	Smoke gas fan
Type/Model	ZRS

fulfils the relevant provisions of following directives and standards

Machinery Directive 2006/42/EC

EN ISO 12100:2010

Safety of machinery – General principles for design - Risk assessment and risk reduction

EN ISO 13857:2019

Safety of machinery – Safety distances to prevent hazard zones being reached by upper or lower limbs

EN 60204-1:2018

Safety of machinery – Electrical equipment of machines – Part 1: General requirements

EN 60335-1:2012

Household and similar electrical appliances – Safety Part 1: General requirements.

EN 60 335-2-80:2003

Household and similar electrical appliances – Safety – Part 2-80: Particular requirements for fans.

EN 50106:2008

Safety of household and similar appliances – Particular rules for routine tests referring to appliances under the scope of EN 60 335-1.

EN 60529:2014

Degrees of protection provided by enclosures (IP Code).

Directive electromagnetic compatibility (EMC) 2014/30/ EU

EN 62233:2008

Measurement methods for electromagnetic fields of household appliances and similar apparatus with regard to human exposure

EN 61000-6-2:2005

Electromagnetic compatibility (EMC) – Part 6-2: Generic standards – Immunity for industrial environments.

RoHS Directive 2011/65/EU and amendment (EU) 2015/ 863

EN IEC 63000:2018

Technical documentation for the assessment of electrical and electronic products with respect to the restriction of hazardous substances

Ecodesign Directive 2009/125/EC

327/2011 Requirements for fans above 125W

1253/2014 Requirements for ventilation units above 30W

1254/2014 Requirements for energy labelling of residential ventilation units

EN ISO 5801:2017

Fans – Performance testing using standardized airways.

EN 13142:2021

Ventilation for buildings – Components/Products for residential ventilation – required and optional performance characteristics.

Persons authorized to compile the technical file:

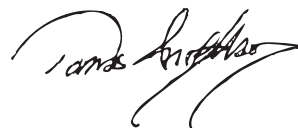

Tomas Angelhag

Head Of Engineering

This declaration relates exclusively to the machinery in the state in which it was placed on the market and excludes components which are added or operations carried out subsequently by the final user.

Skinnskatteberg, Sweden 2023-12-08



Sofia Rask

Managing Director

14 UK Declaration of Conformity

We, the manufacturer

Manufacturer	Systemair Sverige AB
Address	Industrivägen 3 SE-73930 Skinskatteberg Sweden

declare under our sole responsibility that the products

Machine	Smoke gas fan
Type/Model	ZRS

fulfils the relevant provisions of following directives and standards

Supply of Machinery (Safety) Regulations 2008

EN ISO 12100:2010

Safety of machinery – General principles for design - Risk assessment and risk reduction

EN ISO 13857:2019

Safety of machinery – Safety distances to prevent hazard zones being reached by upper or lower limbs

EN 60204-1:2018

Safety of machinery – Electrical equipment of machines – Part 1: General requirements

EN 60335-1:2012

Household and similar electrical appliances – Safety Part 1: General requirements.

EN 60 335-2-80:2003

Household and similar electrical appliances – Safety – Part 2-80: Particular requirements for fans.

EN 50106:2008

Safety of household and similar appliances – Particular rules for routine tests referring to appliances under the scope of EN 60 335-1.

EN 60529:2014

Degrees of protection provided by enclosures (IP Code).

Electromagnetic Compatibility Regulations 2016

EN 62233:2008

Measurement methods for electromagnetic fields of household appliances and similar apparatus with regard to human exposure

EN 61000-6-2:2005

Electromagnetic compatibility (EMC) – Part 6-2: Generic standards – Immunity for industrial environments.

The Restriction of the Use of Certain Hazardous Substances in Electrical and Electronic Equipment Regulations 2012

EN IEC 63000:2018

Technical documentation for the assessment of electrical and electronic products with respect to the restriction of hazardous substances

The Ecodesign for Energy-Related Products and Energy Information (Amendment) (EU Exit) Regulations 2019

327/2011 Requirements for fans above 125W

1253/2014 Requirements for ventilation units above 30W

1254/2014 Requirements for energy labelling of residential ventilation units

EN ISO 5801:2017

Fans – Performance testing using standardized airways.

EN 13142:2021

Ventilation for buildings – Components/Products for residential ventilation – required and optional performance characteristics.

Persons authorized to compile the technical file:

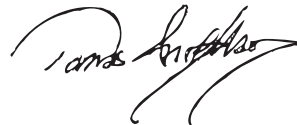

Tomas Angelhag

Head Of Engineering

This declaration relates exclusively to the machinery in the state in which it was placed on the market and excludes components which are added or operations carried out subsequently by the final user.

Skinskatteberg, Sweden 2023-12-08



Sofia Risk

Managing Director



Systemair Sverige AB
Industrivägen 3
SE-739 30 Skinnskatteberg

+46 222 440 00
mailbox@systemair.com
www.systemair.com

© Copyright Systemair AB
All rights reserved
EOE

Systemair AB reserves the rights to alter their products without notice. This also applies to products already ordered, as long as it does not affect the previously agreed specifications.